

Installation and maintenance instructions



uniSTOR HP

VIH RW GB ... BES

GB, IE

Publisher/manufacturer

Vaillant GmbH

Berghauser Str. 40 ■ D-42859 Remscheid
Tel. +492191 18 0 ■ Fax +492191 18 2810
info@vaillant.de ■ www.vaillant.de



Contents

Contents

1	Safety	3
1.1	Action-related warnings	3
1.2	Risk caused by inadequate qualifications.....	3
1.3	Intended use	3
1.4	General safety information	3
1.5	Regulations (directives, laws, standards)	4
2	Notes on the documentation	5
2.1	Observing other applicable documents	5
2.2	Storing documents	5
2.3	Validity of the instructions	5
2.4	Benchmark.....	5
3	Product description	5
3.1	Serial number	5
3.2	Information on the identification plate	5
3.3	CE marking	5
3.4	Hot Water Association	6
4	Set-up	6
4.1	Observing the requirements for the product's installation site	6
4.2	Transport	6
4.3	Unpacking the product.....	7
4.4	Checking the scope of delivery.....	7
4.5	Product dimensionsSlimline	7
4.6	Product dimensions, standard diameter	8
5	Installation	8
5.1	Installing the product.....	8
5.2	Hydraulic connection	8
5.3	Electrical installation	11
6	Start-up	14
6.1	Setting the immersion heater thermostat.....	14
6.2	Cold water inlet pressure	14
6.3	Filling and purging the product	14
6.4	Filling and purging the primary circuit.....	14
7	Handing the product over to the end user	15
8	Troubleshooting	15
8.1	Detecting and eliminating faults.....	15
8.2	Procuring spare parts	15
9	Inspection and maintenance	15
9.1	Observing inspection and maintenance intervals	15
9.2	Draining the product	15
9.3	Checking the safety group's expansion relief valve and the cylinder's expansion relief valve	15
9.4	Checking the pre-charge pressure of the expansion vessel	15
10	Decommissioning the product	15
11	Customer service	15
Appendix	16	
A	Detecting and eliminating faults	16
B	Inspection and maintenance work – Overview	16
C	Technical data	17

D	Commissioning Checklist	19
Index	22	

1 Safety

1.1 Action-related warnings

Classification of action-related warnings

The action-related warnings are classified in accordance with the severity of the possible danger using the following warning signs and signal words:

Warning symbols and signal words



Danger!

Imminent danger to life or risk of severe personal injury



Danger!

Risk of death from electric shock



Warning.

Risk of minor personal injury



Caution.

Risk of material or environmental damage

1.2 Risk caused by inadequate qualifications

The following work must only be carried out by competent persons who are sufficiently qualified to do so:

- Set-up
- Dismantling
- Installation
- Start-up
- Inspection and maintenance
- Repair
- Decommissioning
- ▶ Proceed in accordance with current technology.

1.3 Intended use

There is a risk of injury or death to the user or others, or of damage to the product and other property in the event of improper use or use for which it is not intended.

The product is intended as a system component for domestic hot water generation and storage for closed central heating installations.

Intended use includes the following:

- observance of accompanying operating, installation and maintenance instructions

for the product and any other system components

- installing and setting up the product in accordance with the product and system approval
- compliance with all inspection and maintenance conditions listed in the instructions.

Intended use also covers installation in accordance with the IP code.

Any other use that is not specified in these instructions, or use beyond that specified in this document, shall be considered improper use. Any direct commercial or industrial use is also deemed to be improper.

Caution.

Improper use of any kind is prohibited.

1.4 General safety information

1.4.1 Risk of death due to lack of safety devices

The basic diagrams included in this document do not show all safety devices required for correct installation.

- ▶ Install the necessary safety devices in the installation.
- ▶ Observe the applicable national and international laws, standards and directives.

1.4.2 Risk of death from electric shock

There is a risk of death from electric shock if you touch live components.

Before commencing work on the product:

- ▶ Disconnect the product from the power supply by switching off all power supplies at all poles (electrical partition with a contact gap of at least 3 mm, e.g. fuse or circuit breaker).
- ▶ Secure against being switched back on again.
- ▶ Check that there is no voltage.

1.4.3 Risk of being burned or scalded by hot components

- ▶ Only carry out work on these components once they have cooled down.



1 Safety

1.4.4 Risk of material damage caused by using an unsuitable tool

- ▶ Use the correct tool.

1.4.5 Risk of material damage caused by frost

- ▶ Do not install the product in rooms prone to frost.

1.4.6 Risk of injury due to the heavy weight of the product

- ▶ Make sure that the product is transported by at least two people.

1.5 Regulations (directives, laws, standards)

- ▶ Observe the national regulations, standards, directives, ordinances and laws.

2 Notes on the documentation

2.1 Observing other applicable documents

- ▶ Always observe all the operating and installation instructions included with the system components.

2.2 Storing documents

- ▶ Pass these instructions and all other applicable documents on to the end user.

2.3 Validity of the instructions

These instructions apply only to:

Product article number

VIH RW GB 150 BES	0010019230
VIH RW GB 200 BES	0010019231
VIH RW GB 250 BES	0010019232
VIH RW GB 300 BES	0010019233

2.4 Benchmark

Vaillant is a licensed member of the Benchmark Scheme.

Benchmark places responsibilities on both manufacturers and installers. The purpose is to ensure that customers are provided with the correct equipment for their needs, that it is installed, commissioned and serviced in accordance with the manufacturer's instructions by a competent person approved at the time by the Health and Safety Executive and that it meets the requirements of the appropriate Building Regulations. The Benchmark Checklist can be used to demonstrate compliance with Building Regulations and should be provided to the customer for future reference.

Installers are required to carry out installation, commissioning and servicing work in accordance with the Benchmark Code of Practice which is available from the Heating and Hotwater Industry Council who manage and promote the Scheme.

Benchmark is managed and promoted by the Heating and Hotwater Industry Council.



For more information visit www.centralheating.co.uk

3 Product description

3.1 Serial number

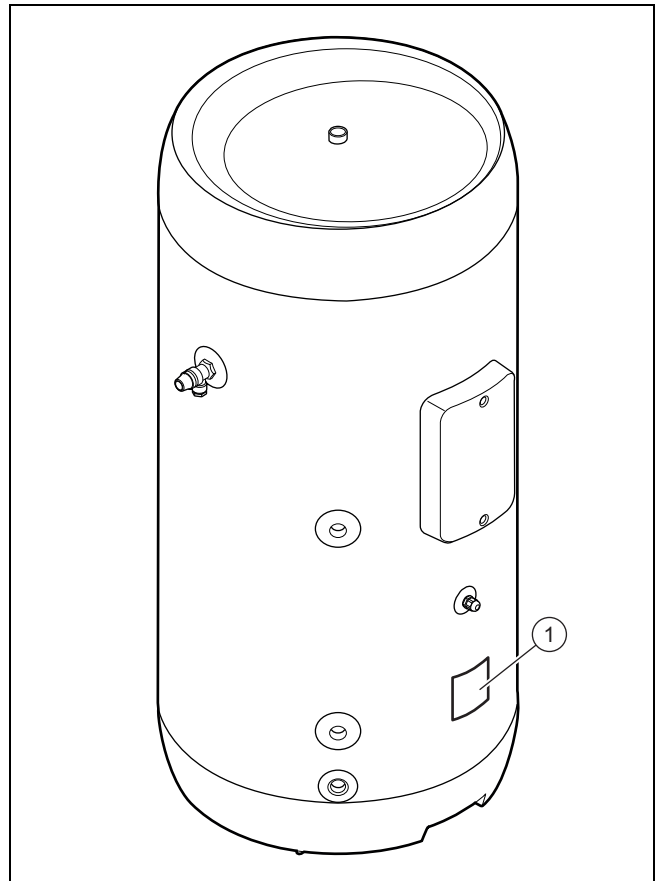

You can find the serial number on the data plate (1), which is located on the cylinder below the electronics box.

3.2 Information on the identification plate

The identification plate is attached to the product at the factory.

The identification plate keeps record of the country in which the product is to be installed.

This product meets the requirements of standard EN 12897:2006.

3.3 CE marking



The CE marking shows that the products comply with the basic requirements of the applicable directives as stated on the declaration of conformity.

The declaration of conformity can be viewed at the manufacturer's site.

4 Set-up

3.4 Hot Water Association

Vaillant is a full member of the Hot Water Association and promotes the scheme in association with its cylinder range. Details are available on the web site www.vaillant.co.uk



4 Set-up

4.1 Observing the requirements for the product's installation site



Caution.
Material damage due to frost

If the water in the system freezes, there is a risk of damage to the domestic hot water cylinder.

- ▶ Install the cylinder in a dry, permanently frost-free room.



Caution.
Material damage due to escaping water

In the event of damage, water may escape from the cylinder.

- ▶ Select the installation location so that, in the event of damage, large volumes of water can be drained safely (e.g. into a floor drain).



Caution.
Material damage due to high load

When filled, the cylinder may damage the ground on which it stands due to its weight.

- ▶ Take into consideration the weight of the filled cylinder and the load-bearing capacity of the floor.
- ▶ If required, reinforce the installation area.

Select a sensible installation site and take into consideration the routing of the pipework system.

Install the cylinder as close as possible to the heat generator in order to minimise heat losses.

Set up the product in a suitable location in a room and, when doing so, pay attention to the following points:

- Plan the installation of the tundish (→ Page 9).
- The installation surface must be even and have sufficient load-bearing capacity to support the operating weight of the product.
- The installation site must be frost-free.

- Install the product in such a way that the thermostat and immersion heater can be accessed easily.
- Leave sufficient space around the product for installing, maintaining and replacing the expansion vessel.

To prevent heat losses, the pipework system must have heat insulation in accordance with the applicable energy-saving regulations.

4.2 Transport



Caution.
Risk of material damage caused by incorrect transport.

The components attached to the cylinder must not be used to transport the cylinder. Otherwise there is a risk that the cylinder could malfunction.

- ▶ Do not use the components attached to the cylinder to transport it.

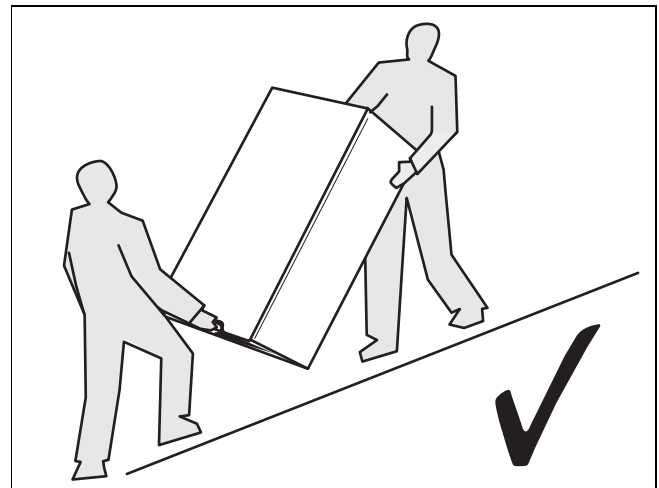

Always transport the unit as illustrated above.

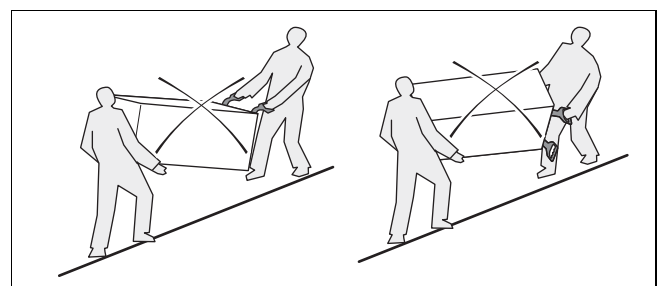

Never transport the unit while it is horizontal.

4.3 Unpacking the product

1. Remove the product from its box.
2. Remove the protective film from all of the product's components.



Caution.

Risk of material damage caused by unpacking incorrectly.

The components could become damaged when unpacking the product.

- Carefully unpack the product.

3. Remove the product from its box.
4. Remove the protective film from all of the product's components.

4.4 Checking the scope of delivery

- Check that the scope of delivery is complete.

Quantity	Designation
1	Domestic hot water cylinder
1	Enclosed documentation
1	Expansion vessel

4.5 Product dimensions Slimline

Validity: VIH RW GB 150 BES

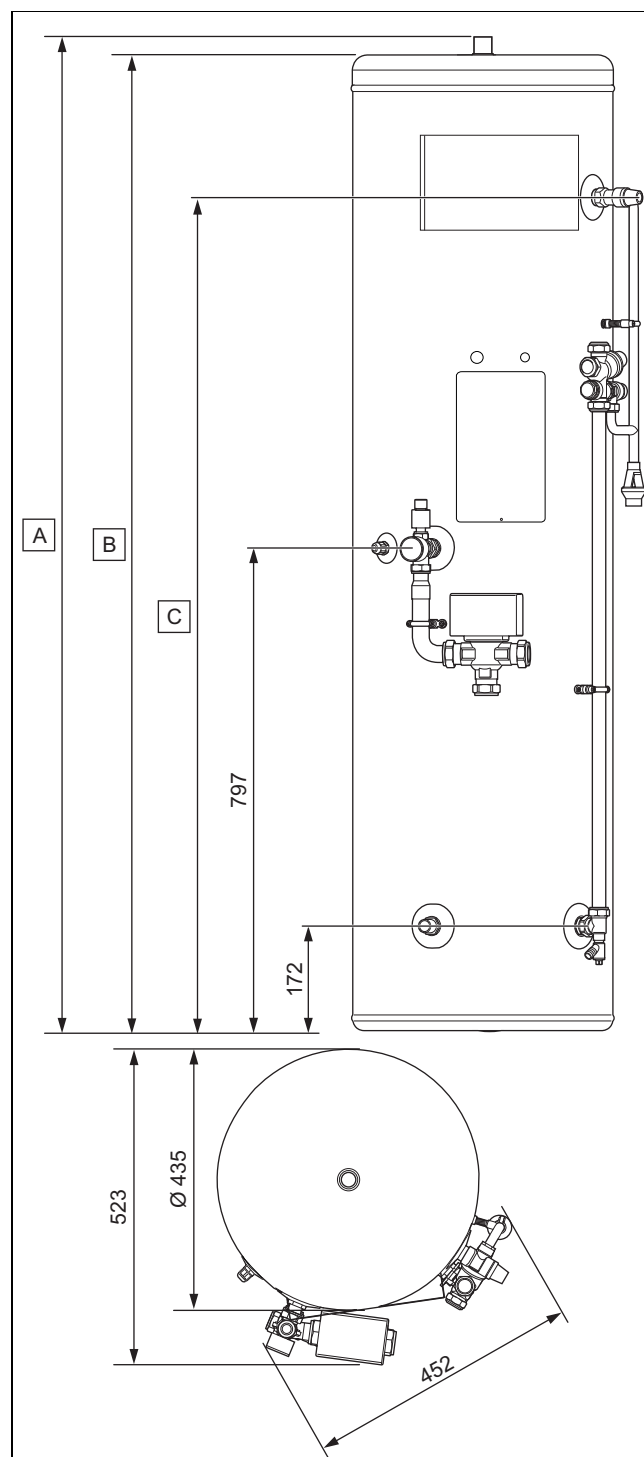

Dimensions (mm)

	A	B	C
VIH RW GB 150 BES	1,642	1,613	1,377

5 Installation

4.6 Product dimensions, standard diameter

Validity: VIH RW GB 200 BES

OR VIH RW GB 250 BES

OR VIH RW GB 300 BES

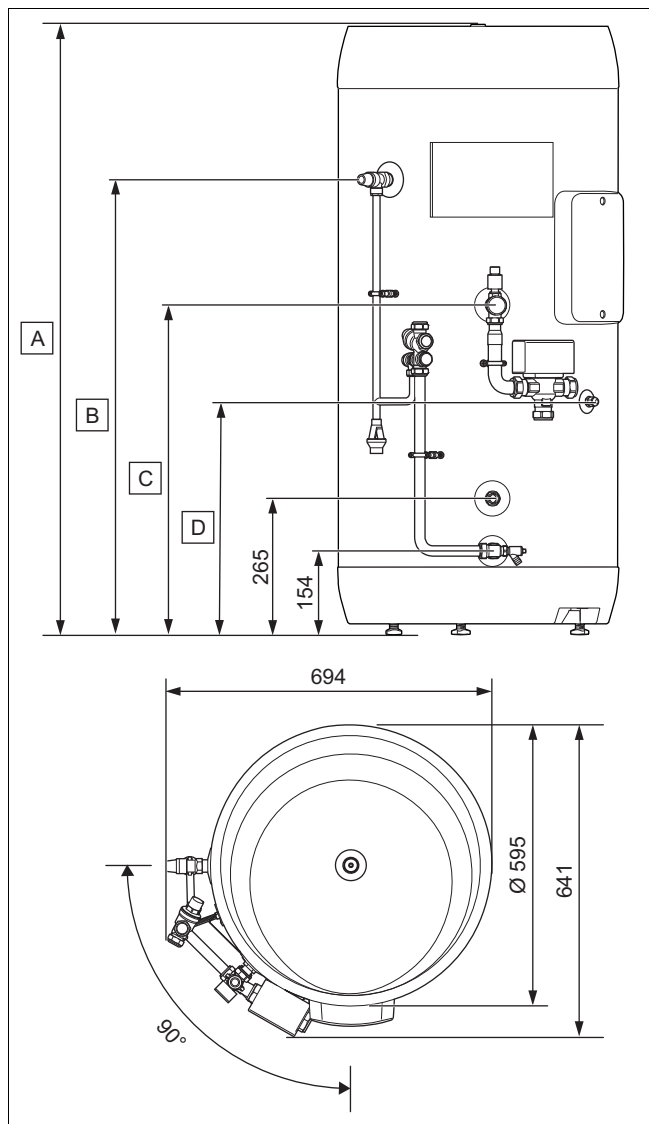

Dimensions (mm)

	A	B	C	D
VIH RW GB 200 BES	1,265	940	675	470
VIH RW GB 250 BES	1,535	1,210	865	565
VIH RW GB 300 BES	1,745	1,420	865	565

5 Installation

5.1 Installing the product

- ▶ Align the product horizontally.

5.2 Hydraulic connection



Caution.

Risk of damage caused by heat transfer when welding.

The heat that is transferred during welding may damage the cylinder and its components as well as the connection seals.

- ▶ Protect the product and its components.
- ▶ Do not weld the connection pieces if these have been screwed into the pipe fittings.



Caution.

Risk of material damage by drilling through the product.

The product may be damaged by drilling work.

- ▶ Do not drill through the product.



Caution.

Risk of material damage to the cylinder.

If an unvented hot water cylinder is fitted at a high level (eg, loft space), potential damage to the cylinder may occur if the correct method of draining is not followed.

- ▶ In certain circumstances and at the discretion of the installer, install a WRAS approved automatic air vent on the hot water outlet at the highest point.

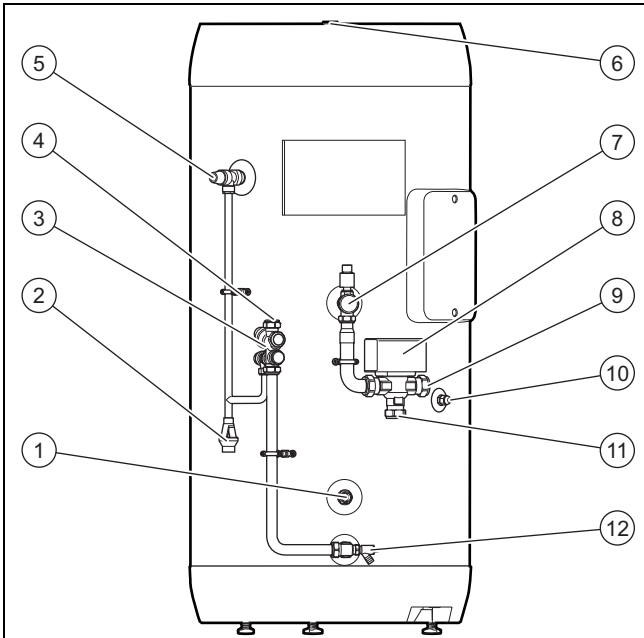

- | | | | |
|---|---|----|---------------------------------------|
| 1 | Cylinder heating return | 7 | Cylinder heating inlet |
| 2 | Tundish | 8 | 3-port motorised valve |
| 3 | Safety group | 9 | Heating circuit heating flow |
| 4 | Cold water inlet | 10 | Dry pocket for the temperature sensor |
| 5 | Domestic hot water expansion relief valve | 11 | Heating flow from the heat pump |
| 6 | Domestic hot water outlet | 12 | Drain valve |

5.2.1 Connecting the product to the brine circuit

- ▶ Connect the brine circuit to the product.
 - Minimum diameter of the copper pipe: ≥ 28 mm



Note

Ensure that the distance between the heat generator and the product is as small as possible in order to prevent heat losses.

5.2.2 Installing an expansion vessel

1. Install the expansion vessel close to the product.
2. Install a pipe at the expansion vessel and connect the terminal to the safety group.

5.2.3 Connecting the installation's cold water supply

- ▶ Connect the cold water inlet to the safety group.

5.2.4 Installing a discharge pipe

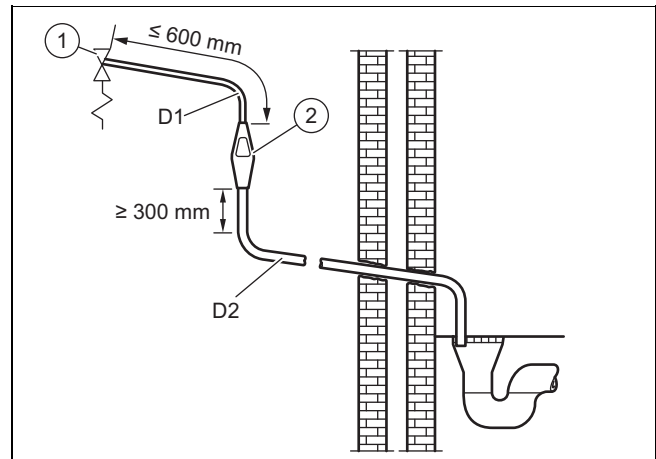

- 1 Temperature and pressure expansion relief valve
 2 Tundish

The drain connections of the temperature and pressure relief valve and the expansion relief valve must be connected to the supplied tundish via 15-mm-thick copper pipes. The tundish must be installed vertically, as close to the cylinder as possible and with a maximum clearance of 600 mm from the connection of the temperature and pressure relief valve. It must be installed in the same room as the cylinder, but at a sufficient distance from electrical components. The drain pipes from the temperature and pressure relief valve and from the expansion relief valve can be connected above the tundish using a T-piece. The drain pipe from the 22 mm connection of the tundish must consist of copper pipes with a diameter of at least 22 mm and be connected to a safe and visible drainage point. The vertical section of pipe beneath the tundish must be at least 300 mm long before any bends or diversions in the line. If the total resistance of the drain pipework exceeds the values in the following table, you must increase the diameter of the pipework. When installing the drain pipework, comply with the standards, directives and laws that are applicable in your country.

Size of the outlet valve	Minimum diameter of the discharge pipe D1	Minimum diameter of the discharge pipe from the tundish D2	Maximum permissible resistance, information on the length of a straight pipe	Resistance per elbow or bend
1/2"	15 mm	22 mm	9 mm	0.8 m
		28 mm	≤ 18 m	1.0 m
		35 mm	≤ 27 m	1.4 m
3/4"	22 mm	28 mm	≤ 9 m	1.0 m
		35 mm	≤ 18 m	1.4 m
		42 mm	≤ 27 m	1.7 m
1"	28 mm	35 mm	≤ 9 m	1.4 m
		42 mm	≤ 18 m	1.7 m
		54 mm	≤ 27 m	2.3 m

Sample calculation

The following example corresponds to a temperature and pressure relief valve G1/2 with a drain pipe (D2) with four 22 mm elbows and a length of 7 m from the tundish to the drain-

5 Installation

age point. According to the table, the maximum permissible resistance for a straight length of a 22-mm-thick copper discharge pipe (D2) of a thermal expansion relief valve G1/2 is 9.0 m. The resistance of the four 22 mm elbows, which are each 0.8 m in length, must be subtracted from this, i.e. a total of 3.2 m. The maximum permitted length is accordingly 5.8 m and is therefore below the current length of 7 m. The calculation must therefore be performed using the second largest size. The maximum permissible resistance for a straight length of a 28-mm-thick pipe (D2) of a thermal expansion relief valve G1/2 is 18 m. The resistance of the four 28 mm elbows, which are each 1.0 m in length, must be subtracted from this, i.e. a total of 4.0 m. The maximum permitted length is accordingly 14 m. As the current length is 7 m, a 28 mm copper pipe (D2) should be selected.

A suitable location for the discharge pipe terminal is, for example, beneath a fixed mesh above the odour trap in a soakaway with a siphon. Low drain pipework, for example up to 100 mm above external surfaces (car parks, meadows, etc.) can be used provided that it is protected by a wire fence or something similar to prevent children from coming into contact with the waste water and provided that the system is not visible. Do not install any valves or stopcocks on the drain pipework.

Make sure that the discharge pipe from the tundish to the drain has a constant downward gradient of at least 1:200. The discharge pipe for the heat generator expansion relief valve can be connected to the horizontal discharge pipe for the cylinder behind the tundish using a T-piece.

5.2.4.1 High-level drain

Installing the highest drain is permitted as long as this does not present a danger to anyone in or outside the building at the drain point. Examples of points to consider when deciding whether a location is suitable for the highest drain:

- The possibility (taking the wind into account) that a person might stay in the area where the water is drained for a prolonged period of time, and, if this is the case, whether the water is sufficiently cooled by that point to pose no danger. The thermal conductivity of the material surfaces, the climatic conditions, the installation location and the drain pipework direction can, to different extents, contribute to reducing the temperature of the water that is being drained.
- The position of the windows and other openings.
- The probability of prams being under the drain opening.
- The resistance of the surface to hot water.
- The possibility of ice forming if water drains onto access paths.

5.2.5 Installing the temperature sensor for the immersion heater



Note

The temperature sensor is used to control the immersion heater via a multi-functional module or a control.

Validity: Except for VIH RW GB 150 BES

Condition: With a multi-functional module or control

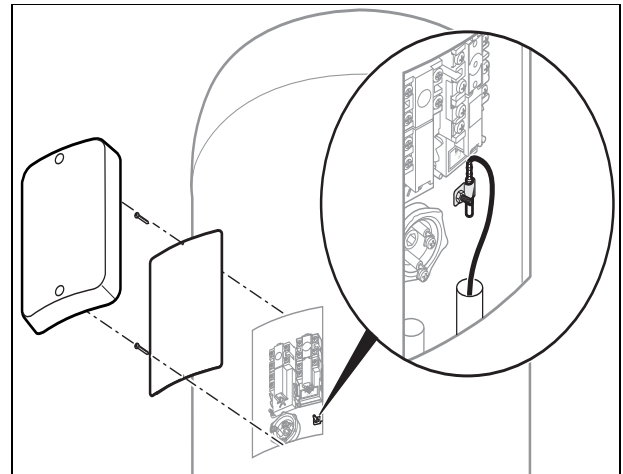

► Secure the temperature sensor.

Validity: VIH RW GB 150 BES

Condition: With a multi-functional module or control

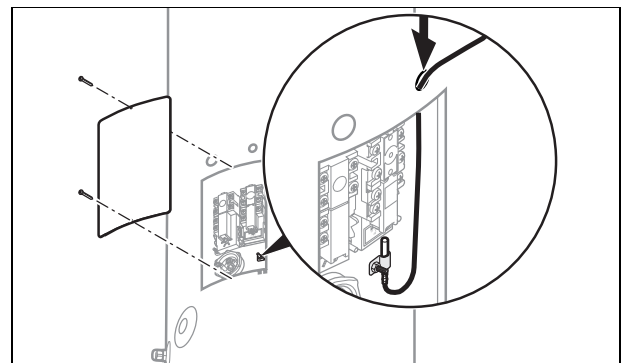

► Secure the temperature sensor.

5.2.6 Secondary return

Validity: VIH RW GB 250 BES
OR VIH RW GB 300 BES

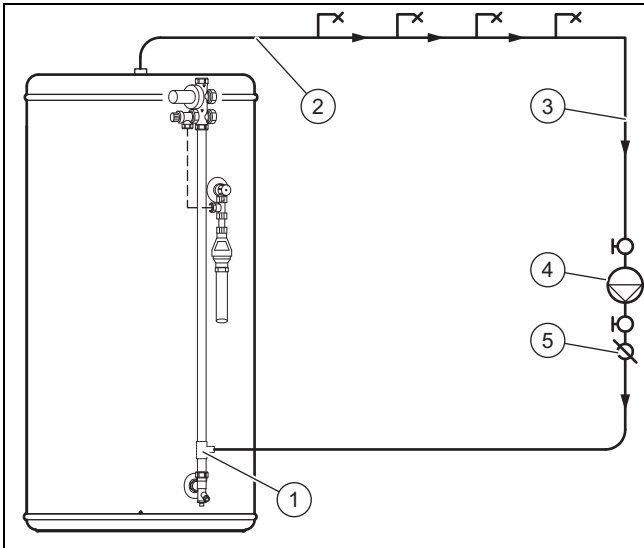

- | | | | |
|---|---|---|-----------------------|
| 1 | T-piece for the secondary return (included in the scope of delivery for the cylinder) | 3 | Secondary return pipe |
| 2 | Domestic hot water outlet | 4 | Circulation pump |
| | | 5 | Non-return valve |

Carry out the installation in accordance with the basic diagram above.

5.3 Electrical installation



Danger!
Risk of death from electric shock!

The power supply terminals L and N are live:

- ▶ Switch off the power supply.
- ▶ Secure the power supply against being switched back on.



Caution.
Risk of material damage by drilling through the product.

The product may be damaged by drilling work.

- ▶ Do not drill through the product.

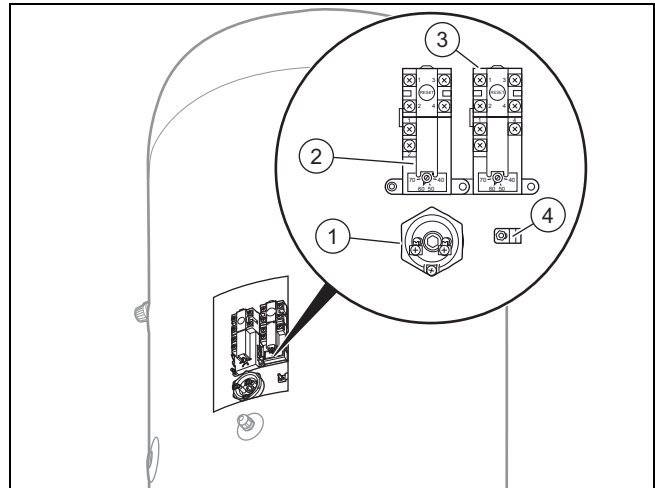

- | | | | |
|---|-----------------------------|---|-------------------------------------|
| 1 | Immersion heater | 3 | Primary circuit thermostat |
| 2 | Immersion heater thermostat | 4 | Retainer for the temperature sensor |

5.3.1 Optional combination of thermostats

Use the wiring diagram in the system instructions for the installation.

5.3.2 Thermostats

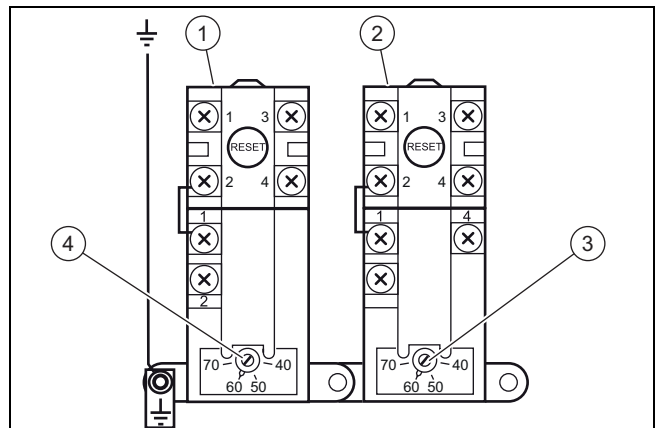

- | | | | |
|---|---|---|--|
| 1 | Thermal cut-out and reset knob for the immersion heater | 3 | Setting the temperature of the primary circuit |
| 2 | Thermal cut-out and reset knob for the primary circuit | 4 | Immersion heater temperature control |

If you are using a control from another brand, use the optional cylinder thermostats.

The thermostat connections make it possible to install a connection box in addition to the Vaillant control.

5 Installation

5.3.3 Thermostats

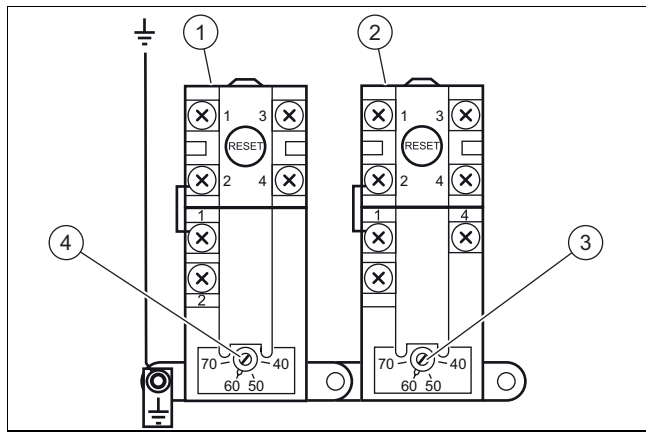

- | | |
|--|---|
| <p>1 Thermal cut-out and reset knob for the immersion heater</p> <p>2 Thermal cut-out and reset knob for the primary circuit</p> | <p>3 Setting the temperature of the primary circuit</p> <p>4 Immersion heater temperature control</p> |
|--|---|

5.3.4 Cable route

Validity: Except for VIH RW GB 150 BES

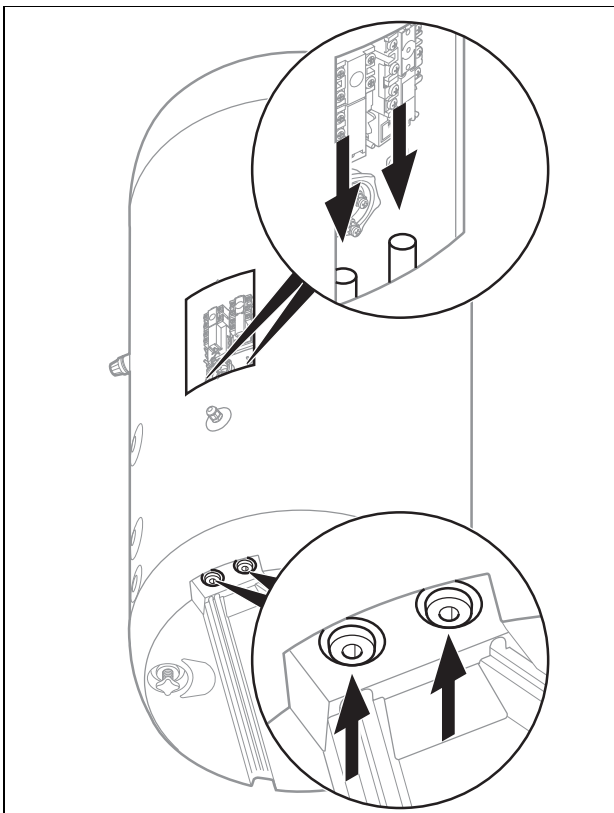

- Use the grommets that are included in the scope of delivery for the cylinder in the electronics box.

Validity: VIH RW GB 150 BES

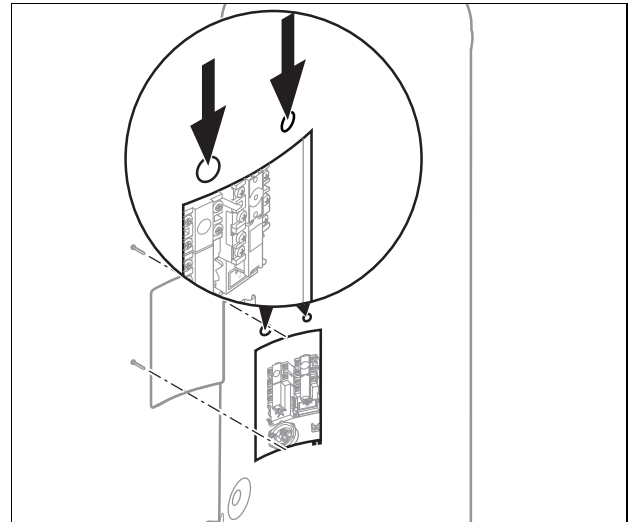

- Use the grommets that are included in the scope of delivery for the cylinder in the electronics box.

5.3.5 Connecting the immersion heater to the power supply

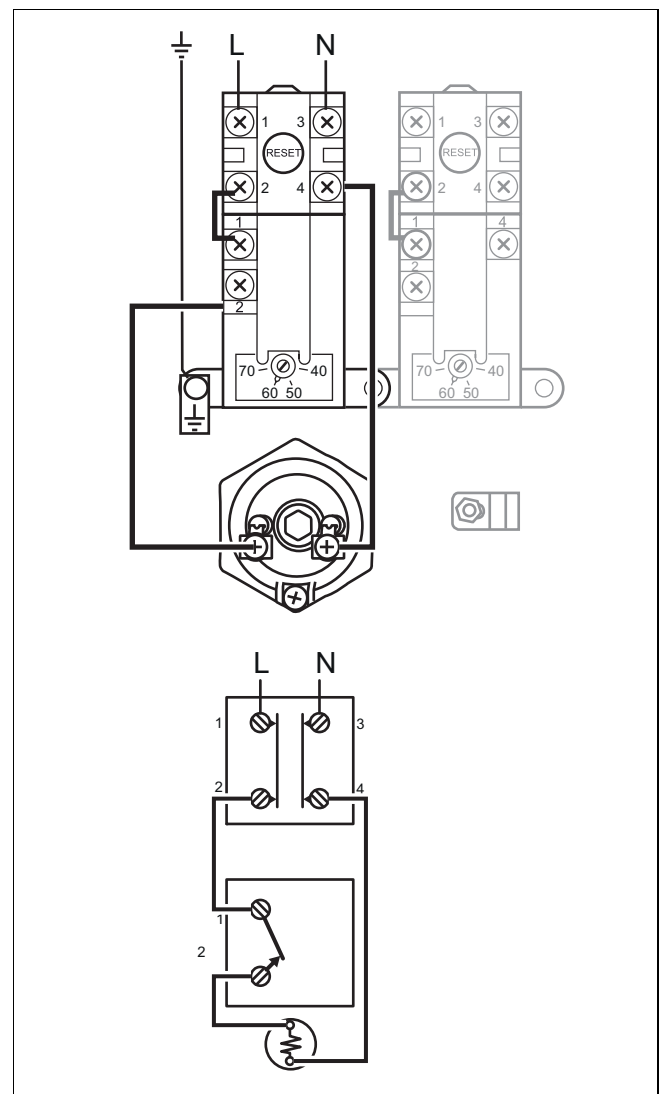

1. Remove the cover for the electrics on the cylinder.

2. Install a separate power supply for the immersion heater in accordance with the applicable standards.
3. Use heat-resistant cables for the immersion heater connection.
 - Diameter of the cable: 1.5 mm²
4. Connect the thermal cut-out to the mains power supply using a double-pole disconnector with a contact gap of at least 3 mm at both poles.
5. Protect the electrical circuit using a fuse.
 - Fuse: 13 A
6. Connect the immersion heater as shown in the basic diagram.
7. Attach the cover for the electrics on the cylinder.

5.3.6 Electrical connection of the temperature sensor

Condition: With a multi-functional module or control

- ▶ Connect the temperature sensor to the multi-functional module or the control; to do this, see the instructions for the control or multi-functional module.

5.3.7 Connecting the control

Condition: eBUS

The thermal cut-out for the primary circuit is not used when connecting an eBUS unit.

Condition: 230 V control

If you use a 230 V control from a third-party manufacturer, connect the thermal cut-out (2) and (3) for the primary circuit to the motorised valve to isolate the heat source in the event of a fault in the motorised valve.

5.3.8 Electric connection for the primary circuit

1. Connect the thermostat for the primary circuit and the thermal cut-out.
 - Diameter of the cable: 1.5 mm²

Condition: S plan

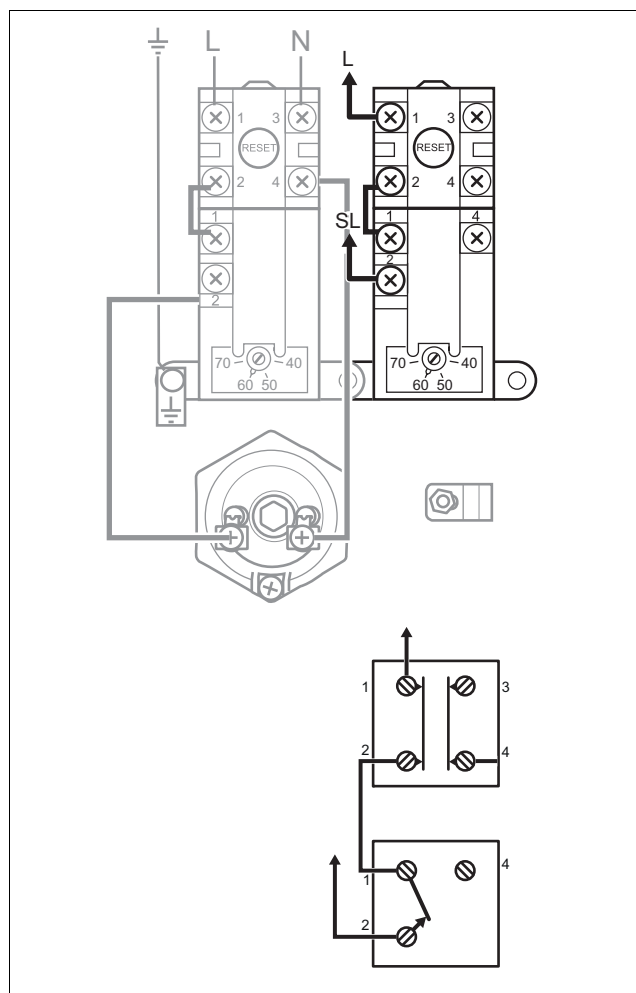

- ▶ Connect the assembly.

6 Start-up

Condition: Y plan

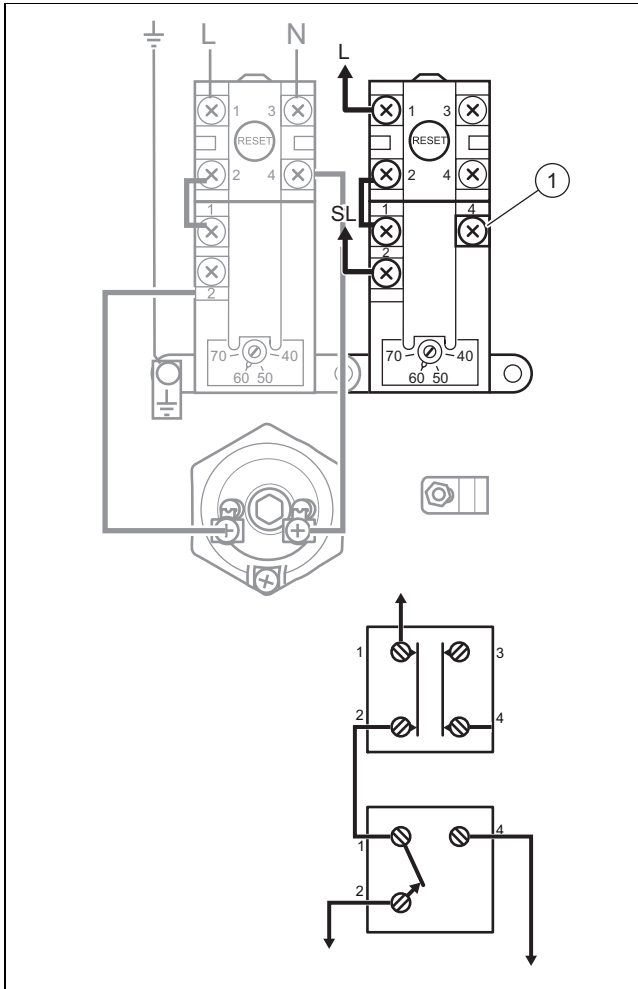

- ▶ Connect the plug (1) to the electronics box.

5.3.9 Establishing the electrical connection for the motorised valve

- ▶ Establish the electrical connection for the motorised valve.

6 Start-up

6.1 Setting the immersion heater thermostat

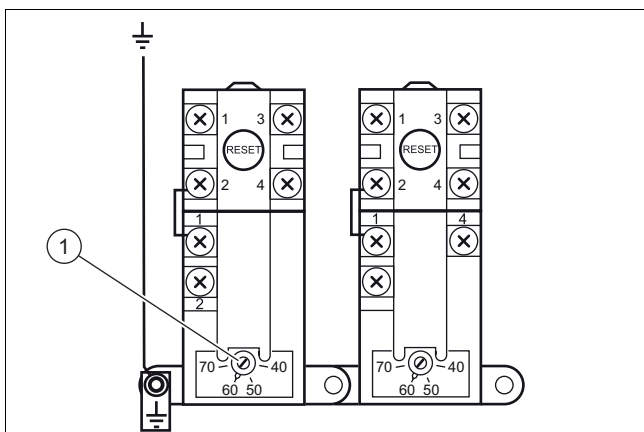

The domestic hot water temperature is controlled via the immersion heater thermostat (1).

Condition: Without a multi-functional module or control

- ▶ Set the domestic hot water temperature as desired.

Condition: With multi-functional module or control

- ▶ Set the immersion heater thermostat (1) to its maximum.

The temperature of the immersion heater is regulated via the temperature sensor that is installed on the carrier in the electronics box.

6.2 Cold water inlet pressure

The product's efficiency depends on the cold water inlet pressure.

To achieve optimum efficiency, we recommend a pressure of at least 2 bar.

6.3 Filling and purging the product



Note

It is not permitted to use valves or expansion relief valves for the purging.

1. Check whether the drain valve is closed.
2. Open the domestic hot water draw-off valves.
3. Open the water supply valve.
4. Open the manual air separator at the top of the cylinder.
5. Let the water flow in order to remove any air bubbles.
6. Close the manual air separator as soon as all of the air has escaped.
7. Close the domestic hot water draw-off valves.
8. Check whether there are any leaks. Check the immersion heater in particular.
9. Open the highest hot water supply valve, and then the lowest hot water supply valve, and let the water flow.
 - Water running time: ≥ 5 min
10. Close all of the draw-off valves.

6.4 Filling and purging the primary circuit



Note

The primary circuit can be filled using a filling device or a separate filling cock, which is installed at a location that is easily accessible.

The separate filling cock must be removed after filling.

If a filling device is used, close the filling valve and remove the filling device.

Legal requirements mean that you must not use a separate filling tap. Use a pump.

1. Move the lever to MAN OPEN and hold it in this position.
2. Flush out the primary circuit and then fill and purge it. Consult the installation instructions for the heat generator.
3. Move the lever to AUTO.
4. Remove the cover for the electrics.
5. Set the product's thermostat and the immersion heater's thermostat.

- Setting the thermostats: 60 °C
- 6. Start up the heat generator.
- 7. Drain the heating circuit as soon as the operating temperature has been reached in order to remove any residue from the heating installation.
- 8. Fill and purge the primary circuit. Consult the installation instructions for the heat generator.

7 Handing the product over to the end user

- ▶ Once the installation is complete, show the user the location and function of the safety devices.
- ▶ Inform the end user how to handle the product.
- ▶ In particular, draw attention to the safety warnings which the end user must follow.
- ▶ Inform the end user of the necessity to have the product maintained according to the specified intervals.

8 Troubleshooting

8.1 Detecting and eliminating faults

- ▶ If problems occur whilst operating the product, check certain points with the aid of the table in the appendix. Detecting and eliminating faults (→ Page 16)

8.2 Procuring spare parts

The original components of the product were also certified by the manufacturer as part of the declaration of conformity. If you use other, non-certified or unauthorised parts during maintenance or repair work, this may void the conformity of the product and it will therefore no longer comply with the applicable standards.

We strongly recommend that you use original spare parts from the manufacturer as this guarantees fault-free and safe operation of the product. To receive information about the available original spare parts, contact the contact address provided on the back page of these instructions.

- ▶ If you require spare parts for maintenance or repair work, use only the spare parts that are permitted for the product.

9 Inspection and maintenance

9.1 Observing inspection and maintenance intervals

Adhere to the minimum inspection and maintenance intervals. The inspection may require maintenance to be carried out earlier, depending on the results.

Inspection and maintenance work – Overview (→ Page 16)

The immersion heater can be removed in order to inspect the inside of the cylinder.

9.2 Draining the product

1. Close the cold water draw-off valve.
2. Secure a hose to the drain valve.
3. Position the hose at a suitable drain.
4. Open the highest hot water tap in the installation.
5. Open the drain valve and drain the product completely.
6. Close the hot water tap and the drain valve.
7. Remove the hose.

9.3 Checking the safety group's expansion relief valve and the cylinder's expansion relief valve

1. Open all expansion relief valves by turning the plug.
2. Check whether the water is flowing into the tundish.
3. Check that the expansion relief valves are in the correct position and then check the pressure.
4. Check and, if required, clean the pressure reducer.

9.4 Checking the pre-charge pressure of the expansion vessel

1. Drain the product. (→ Page 15)
2. Measure the pre-charge pressure of the expansion vessel at the vessel valve.

Condition: Pressure <0.3 MPa (0.3 bar)

- ▶ Top up the expansion vessel in accordance with the static height of the heating installation, ideally with nitrogen, otherwise with air.
- 3. If water escapes from the valve of the expansion vessel, you must replace the expansion vessel.
- 4. Fill and purge the product. (→ Page 14)

10 Decommissioning the product

- ▶ Switch off the heat generator.
- ▶ Unplug the domestic hot water cylinder's mains plug.
- ▶ Close the cold-water stopcock.
- ▶ Drain the product. (→ Page 15)
- ▶ Remove the hydraulic connections and the temperature sensor.
- ▶ Remove the cables for the temperature sensor from the heat generator, control or multi-functional module.

11 Customer service

To ensure regular servicing, it is strongly recommended that arrangements are made for a Maintenance Agreement. Please contact Vaillant Service Solutions for further details:

Telephone: 0330 100 3461

Appendix

A Detecting and eliminating faults

Fault	Possible cause	Remedy
No flow rate at the valve	<ol style="list-style-type: none"> 1. Water supply valve closed 2. Main filter blocked 3. Pressure reducer not installed correctly 	<ol style="list-style-type: none"> 1. Check and open the valve. 2. Close the water supply valve, clean the filter and the water pressure reducer. 3. Check whether the pressure reducer has been installed correctly.
Low throughput and pressure at a valve	<ol style="list-style-type: none"> 1. Filter in cold water supply clogged 	<ol style="list-style-type: none"> 1. Close the cold water supply, clean the filter for the water pressure reducer.
Water from the valve is cold	<ol style="list-style-type: none"> 1. The cylinder was not set or is not operating. 2. The heat generator does not work. 3. The thermal cut-out was triggered. 4. Motorised valve does not work 5. The immersion heater does not work. 	<ol style="list-style-type: none"> 1. Check the thermostat or the room thermostat and, if required, set this. 2. Check the heat generator; a fault code is present. 3. Check and initialise the cylinder. 4. Check the valve's connections. 5. Set the thermostat or the room thermostat.
Domestic hot water temperature too high	<ol style="list-style-type: none"> 1. Use a thermometer to check the temperature; it must be between 60 and 65 °C. 2. Check the cabling. 3. Thermostat set too high 4. Defective thermostat 	<ol style="list-style-type: none"> 1. Install a mixer tap. 2. Repair the cable. 3. Reduce the temperature of the thermostat to 55 °C. 4. Replace the thermostat.
Irregular domestic hot water output at the valve	<ol style="list-style-type: none"> 1. Defective expansion vessel 2. Thermal control 	<ol style="list-style-type: none"> 1. Set the expansion vessel. 2. Interrupt the power supply of the product and heat generator, check the thermal cut-outs and replace these if you find any defects.
Continuous water leak (dripping)	<ol style="list-style-type: none"> 1. Expansion relief valve fault 2. Temperature and pressure relief valve fault. 	<ol style="list-style-type: none"> 1. Determine the part that is causing the continuous water leak. 2. Replace the defective parts.
Continuous water leak (flowing out quickly)	<ol style="list-style-type: none"> 1. Malfunction in the pressure reducer. 	<ol style="list-style-type: none"> 1. Check the pressure at the pressure reducer outlet. 2. Replace the pressure reducer if the pressure is above 3.5 bar.
Continuous water leak (flowing out quickly with hot water vapour)	<ol style="list-style-type: none"> 1. Temperature and pressure relief valve opened due to an excessively high temperature. 	<ol style="list-style-type: none"> 1. Switch off the power supply to the immersion heater. 2. If the immersion heater is not switched on, switch off the power supply to the cylinder. 3. Contact a competent person.

B Inspection and maintenance work – Overview

N°	Work	Maintenance-related interval
1	Check the connections for tightness.	Annually
2	Check the temperature and pressure expansion relief valve.	Annually
3	Check the expansion relief valve.	Annually
4	Check the pressure in the expansion vessel.	Annually
5	Check the domestic hot water output at the valve (if required, clean the filters).	Annually
6	Check the target domestic hot water temperature.	Annually
7	Fill out the cylinder's benchmark checklist.	Annually

C Technical data

Technical data – General

	VIH RW GB 150 BES	VIH RW GB 200 BES	VIH RW GB 250 BES	VIH RW GB 300 BES
Actual volumetric capacity	139.5 l	190.7 l	236.3 l	273.5 l
Hot water volumetric capacity in accordance with EN 12897	127.0 l	172.5 l	211.0 l	208.0 l
Maximum pressure of the heating tube coil during operation	0.35 MPa (3.50 bar)	0.35 MPa (3.50 bar)	0.35 MPa (3.50 bar)	0.35 MPa (3.50 bar)
Operating pressure	0.35 MPa (3.50 bar)	0.35 MPa (3.50 bar)	0.35 MPa (3.50 bar)	0.35 MPa (3.50 bar)
Maximum operating pressure	0.7 MPa (7.0 bar)	0.7 MPa (7.0 bar)	0.7 MPa (7.0 bar)	0.7 MPa (7.0 bar)
Pressure of the pressure reducer	0.35 MPa (3.50 bar)	0.35 MPa (3.50 bar)	0.35 MPa (3.50 bar)	0.35 MPa (3.50 bar)
Opening pressure in the expansion relief valve	0.6 MPa (6.0 bar)	0.6 MPa (6.0 bar)	0.6 MPa (6.0 bar)	0.6 MPa (6.0 bar)
Temperature and pressure expansion relief valve	0.7 MPa (7.0 bar)	0.7 MPa (7.0 bar)	0.7 MPa (7.0 bar)	0.7 MPa (7.0 bar)
Temperature and pressure expansion relief valve	90 °C	90 °C	90 °C	90 °C
Load pressure in the expansion vessel	0.3 MPa (3.0 bar)	0.3 MPa (3.0 bar)	0.3 MPa (3.0 bar)	0.3 MPa (3.0 bar)
Maximum temperature of the heating circuit	95 °C	95 °C	95 °C	95 °C
Maximum domestic hot water temperature	85 °C	85 °C	85 °C	85 °C
Heat loss (24 h), energy efficiency class: C	1.80 kWh	1.22 kWh	1.41 kWh	1.59 kWh
Reheating time in accordance with EN 12897	18.49 min	20.83 min	15.08 min	10.66 min
Reheating time (70%)	12.94 min	14.58 min	10.55 min	7.46 min
Reheating output	21.7 kW	26.0 kW	40.7 kW	52.5 kW
Flow rate	900 l/h	900 l/h	900 l/h	1,400 l/h
Pressure loss in the heat exchanger	70 mbar	100 mbar	170 mbar	200 mbar
Volume of the heat exchanger	5.6 l	7.7 l	12.9 l	15.20 l
Surface of the heat exchanger	1.0 m ²	1.4 m ²	2.4 m ²	2.8 m ²
Volume of the expansion vessel	12 l	18 l	25 l	25 l
Tilt measurement	1,680 mm	1,390 mm	1,640 mm	1,840 mm
Net weight	54.5 kg	58.0 kg	73.3 kg	80.6 kg
Weight including heating water and domestic hot water	199.6 kg	256.4 kg	322.5 kg	369.3 kg

Technical data – Hydraulic connection

	VIH RW GB 150 BES	VIH RW GB 200 BES	VIH RW GB 250 BES	VIH RW GB 300 BES
Diameter of the cold water supply pipe	3/4"	3/4"	3/4"	3/4"
Hot water outlet	3/4"	3/4"	3/4"	3/4"
Heat generator heating flow	3/4	3/4	3/4	3/4
Heat generator heating return	3/4	3/4	3/4	3/4

	VIH RW GB 150 BES	VIH RW GB 200 BES	VIH RW GB 250 BES	VIH RW GB 300 BES
Temperature dry pocket	8 mm	8 mm	8 mm	8 mm
Immersion heater diameter	1"	1 1/4"	1 1/4"	1 1/4"

Technical data – Electrics

	VIH RW GB 150 BES	VIH RW GB 200 BES	VIH RW GB 250 BES	VIH RW GB 300 BES
Connecting the immersion heater to the power supply	230 V / 50 Hz	230 V / 50 Hz	230 V / 50 Hz	230 V / 50 Hz
Immersion heater power	2.8 kW	2.8 kW	2.8 kW	2.8 kW
Low loss header	230/240 V, 50Hz	230/240 V, 50Hz	230/240 V, 50Hz	230/240 V, 50Hz
Thermostat	230/240 V, 50Hz	230/240 V, 50Hz	230/240 V, 50Hz	230/240 V, 50Hz
IP rating	21	21	21	21

Technical data – Material

	VIH RW GB 150 BES	VIH RW GB 200 BES	VIH RW GB 250 BES	VIH RW GB 300 BES
Cylinder material	Stainless steel (1.4521)	Stainless steel (1.4521)	Stainless steel (1.4521)	Stainless steel (1.4521)
Insulation material	Polyurethane	Polyurethane	Polyurethane	Polyurethane
Insulation thickness	40 mm	50 mm	50 mm	50 mm
Propellant for insulating material	GWP < 5	GWP < 5	GWP < 5	GWP < 5
ODP	0	0	0	0

D Commissioning Checklist

Benchmark Commissioning and Servicing Section

It is a requirement that the cylinder is installed and commissioned to the manufacturers instructions and the data fields on the commissioning checklist completed in full.

To instigate the cylinder guarantee the cylinder needs to be registered with the manufacturer within one month of the installation.

To maintain the cylinder guarantee it is essential that the cylinder is serviced annually by a competent person who has been trained on the cylinder installed. The service details should be recorded on the Benchmark Service Interval Record and left with the householder.



www.centralheating.co.uk

MAINS PRESSURE HOT WATER STORAGE SYSTEM COMMISSIONING CHECKLIST

This Commissioning Checklist is to be completed in full by the competent person who commissioned the storage system as a means of demonstrating compliance with the appropriate Building Regulations and then handed to the customer to keep for future reference.

Failure to install and commission this equipment to the manufacturer's instructions may invalidate the warranty but does not affect statutory rights.

Customer name:		Telephone number:	
Address:			
Cylinder Make and Model			
Cylinder Serial Number			
Commissioned by (PRINT NAME):		Registered Operative ID Number	
Company name:		Telephone number:	
Company address:			
		Commissioning date:	
To be completed by the customer on receipt of a Building Regulations Compliance Certificate*:			
Building Regulations Notification Number (if applicable)			
ALL SYSTEMS PRIMARY SETTINGS (indirect heating only)			
Is the primary circuit a sealed or open vented system?		Sealed	Open
What is the maximum primary flow temperature?			°C
ALL SYSTEMS			
What is the incoming static cold water pressure at the inlet to the system?			bar
Has a strainer been cleaned of installation debris (if fitted)?		Yes	No
Is the installation in a hard water area (above 200ppm)?		Yes	No
If yes, has a water scale reducer been fitted?		Yes	No
What type of scale reducer has been fitted?			
What is the hot water thermostat set temperature?			°C
What is the maximum hot water flow rate at set thermostat temperature (measured at high flow outlet)?			l/min
Time and temperature controls have been fitted in compliance with Part L of the Building Regulations?		Yes	
Type of control system (if applicable)		Y Plan	S Plan
Is the cylinder solar (or other renewable) compatible?		Yes	No
What is the hot water temperature at the nearest outlet?			°C
All appropriate pipes have been insulated up to 1 metre or the point where they become concealed		Yes	
UNVENTED SYSTEMS ONLY			
Where is the pressure reducing valve situated (if fitted)?			
What is the pressure reducing valve setting?			bar
Has a combined temperature and pressure relief valve and expansion valve been fitted and discharge tested?		Yes	No
The tundish and discharge pipework have been connected and terminated to Part G of the Building Regulations		Yes	
Are all energy sources fitted with a cut out device?		Yes	No
Has the expansion vessel or internal air space been checked?		Yes	No
THERMAL STORES ONLY			
What store temperature is achievable?			°C
What is the maximum hot water temperature?			°C
ALL INSTALLATIONS			
The hot water system complies with the appropriate Building Regulations		Yes	
The system has been installed and commissioned in accordance with the manufacturer's instructions		Yes	
The system controls have been demonstrated to and understood by the customer		Yes	
The manufacturer's literature, including Benchmark Checklist and Service Record, has been explained and left with the customer		Yes	
Commissioning Engineer's Signature			
Customer's Signature			
(To confirm satisfactory demonstration and receipt of manufacturer's literature)			

*All installations in England and Wales must be notified to Local Authority Building Control (LABC) either directly or through a Competent Persons Scheme. A Building Regulations Compliance Certificate will then be issued to the customer.



SERVICE RECORD

It is recommended that your hot water system is serviced regularly and that the appropriate Service Record is completed.

Service Provider

Before completing the appropriate Service Record below, please ensure you have carried out the service as described in the manufacturer's instructions.

SERVICE 01		Date:	SERVICE 02		Date:
Engineer name:			Engineer name:		
Company name:			Company name:		
Telephone No:			Telephone No:		
Comments:			Comments:		
.....				
.....				
.....				
.....				
Signature			Signature		
SERVICE 03		Date:	SERVICE 04		Date:
Engineer name:			Engineer name:		
Company name:			Company name:		
Telephone No:			Telephone No:		
Comments:			Comments:		
.....				
.....				
.....				
.....				
Signature			Signature		
SERVICE 05		Date:	SERVICE 06		Date:
Engineer name:			Engineer name:		
Company name:			Company name:		
Telephone No:			Telephone No:		
Comments:			Comments:		
.....				
.....				
.....				
.....				
Signature			Signature		
SERVICE 07		Date:	SERVICE 08		Date:
Engineer name:			Engineer name:		
Company name:			Company name:		
Telephone No:			Telephone No:		
Comments:			Comments:		
.....				
.....				
.....				
.....				
Signature			Signature		
SERVICE 09		Date:	SERVICE 10		Date:
Engineer name:			Engineer name:		
Company name:			Company name:		
Telephone No:			Telephone No:		
Comments:			Comments:		
.....				
.....				
.....				
.....				
Signature			Signature		

Index

A	
Article number	5
B	
Basic diagram.....	3
C	
CE marking.....	5
Checking the pre-charge pressure of the expansion vessel	15
Competent person.....	3
D	
Decommissioning.....	15
Decommissioning the product.....	15
Discharge pipe	9
Documents	5
Draining the product.....	15
E	
Electricity	3
F	
Filling and purging the primary circuit.....	14
Filling and purging the product.....	14
Frost	4
H	
Handing over to the end user	15
I	
Identification plate	5
Inspection work	15–16
Intended use.....	3
M	
Maintenance work	15
P	
Product dimensions.....	7–8
Q	
Qualification.....	3
R	
Regulations	4
S	
Safety device.....	3
Serial number.....	5
Spare parts.....	15
T	
Tool	4
Transport.....	4
Troubleshooting.....	15
U	
Unpacking the product	7
V	
Voltage	3

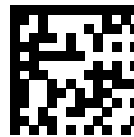

0020221303_02

0020221303_02 ■ 29.11.2019

Supplier

Vaillant Ltd.

Nottingham Road ■ Belper ■ Derbyshire ■ DE56 1JT

Telephone 0330 100 3461

info@vaillant.co.uk ■ www.vaillant.co.uk

© These instructions, or parts thereof, are protected by copyright and may be reproduced or distributed only with the manufacturer's written consent.

Subject to technical modifications.