

For the competent person

Installation and maintenance instructions



allSTOR buffer cylinder

VPS 300/3, VPS 500/3, VPS 800/3, VPS 1000/3,
VPS 1500/3, VPS 2000/3

GB

Publisher/manufacturer

Vaillant GmbH

Berghauser Str. 40 ■ D-42859 Remscheid
Telefon 021 91 18-0 ■ Telefax 021 91 18-28 10
info@vaillant.de ■ www.vaillant.de



Contents

Contents

1	Safety	3
1.1	Action-related warnings	3
1.2	Intended use	3
1.3	General safety information	3
1.4	Regulations.....	4
2	Notes on the documentation	5
2.1	Observing other applicable documents	5
2.2	Storing documents.....	5
2.3	Applicability of the instructions	5
3	Description of the unit and functions	5
3.1	Design.....	5
3.2	Functionality.....	5
4	Installation	6
4.1	Checking the scope of delivery.....	6
4.2	Checking the requirements for the installation site	6
4.3	Transporting the buffer cylinder	7
4.4	Unpacking and setting up the buffer cylinder	7
4.5	Preparing the piping.....	7
4.6	Installing the heat insulation	7
4.7	Installing the buffer cylinder piping	9
5	Start-up	9
5.1	Filling and purging the buffer cylinder.....	9
5.2	Completing start-up	9
6	Handing over to the operator	10
7	Troubleshooting	10
8	Inspection, maintenance and spare parts	10
8.1	Maintenance plan	10
8.2	Checking the connections for leaks	10
8.3	Purging the buffer cylinder.....	10
8.4	Filling the buffer cylinder.....	10
8.5	Check the connections, heat insulation and components for damage	10
8.6	Caring for the product.....	10
8.7	Procuring spare parts	11
9	Decommissioning	11
9.1	Emptying the buffer cylinder	11
9.2	Decommissioning components.....	11
10	Recycling and disposal	11
11	Technical data	12
11.1	Connection dimensions	12
11.2	Technical data table.....	12
11.3	Connection sizes	13
12	allSTOR buffer cylinder system	14
12.1	System description	14
12.2	Designing the system	14
12.3	Hydraulic scheme	15
12.4	Starting up the system	16
13	Customer service	16



1 Safety

1.1 Action-related warnings

Classification of action-related warnings

The action-related warnings are classified in accordance with the severity of the possible danger using the following warning signs and signal words:

Warning symbols and signal words



Danger!

Imminent danger to life or risk of severe personal injury



Danger!

Risk of death from electric shock



Warning.

Risk of minor personal injury



Caution.

Risk of material or environmental damage

1.2 Intended use

In the event of inappropriate or improper use, damage to the product and other property may arise.

The product is specially designed for closed central heating in households, sports facilities and businesses. All heat generators, including combinations of these, are considered.

Intended use includes the following:

- observance of accompanying operating, installation and servicing instructions for the product and any other system components
- installing and fitting the product in accordance with the product and system approval
- compliance with all inspection and maintenance conditions listed in the instructions.

Intended use also covers installation in accordance with the IP class.

Any other use that is not specified in these instructions, or use beyond that specified in this document shall be considered improper use. Any direct commercial or industrial use is also deemed to be improper.

Caution.

Improper use of any kind is prohibited.

1.3 General safety information

1.3.1 Risk of death due to lack of safety devices

A lack of safety devices (e.g. expansion relief valve, expansion vessel) can lead to potentially fatal scalding and other injuries, e.g. due to explosions. The schematic drawings included in this document do not show all safety devices required for correct installation.

- ▶ Install the necessary safety devices in the system.
- ▶ Inform the operator about the function and position of the safety devices.
- ▶ Observe the applicable national and international laws, standards and guidelines.

1.3.2 Risk of frost

If the product is placed out of operation for a relatively long period of time (e.g. during a winter holiday) in an unheated room, the heating water in the product and pipelines may freeze.

- ▶ Install the buffer cylinder in a dry and permanently frost-free installation room.

1.3.3 Risk of material damage caused by using an unsuitable tool

- ▶ Use the correct tool to tighten or loosen screw connections.

1.3.4 Material damage due to leaks

- ▶ Ensure that there is no mechanical tension on the supply lines.
- ▶ Do not suspend any loads from the pipelines (e.g. clothing).

1.3.5 Danger due to changes to the product environment

- ▶ If changes to the product's surroundings may affect the operational safety of the system, do not make any changes to the following:
 - to the product itself
 - to the gas, air, water and electricity supplies
 - to the drain line and expansion relief valve for the heating water
 - to the structural elements





1 Safety

1.3.6 Material damage due to water that is too hard

Water that is too hard may impair the system's functionality and cause damage in a short period of time.

- ▶ Ask your local water company about the water hardness.
- ▶ When deciding whether the water used must be softened, follow directive VDI 2035.
- ▶ In the installation and servicing instructions for the unit that your system comprises, you can read the qualities that the water that is used must have.

1.4 Regulations

1.4.1 Regulations (directives, laws, standards)

As part of the installation, commissioning and operation of the heat pump and the DHW storage you must take into account the current versions of the following regulations or standards, along with any local directives or guidelines that may apply.

- Electricity at work act.
- Health and safety at work act.
- Relevant Utility supplier's regulations.
- Water regulations and by-laws.
- Environment agency and local council requirements regarding bore holes, water courses, or noise levels.
- Gas safety installation and use regulations concerning any associated gas fired heat source used within the heating system.
- Building regulations part "L" and directives concerning energy saving.
- Building Regulations part "G", particularly G3 covering Hygiene.
- HSE Approved Code of Practice and guidance L8, The control of Legionella bacteria in water systems.
- COSHH regulations.
- Other relevant bodies such as HETAS and OFTEC.



2 Notes on the documentation

2.1 Observing other applicable documents

- ▶ You must observe all the operating and installation instructions included with the system components.

2.2 Storing documents

- ▶ Pass these instructions and all other applicable documents on to the system operator.

2.3 Applicability of the instructions

These instructions apply for the following products only:

Type designation	Article number
VPS 300/3-5 INT	0010015130
VPS 500/3-5 INT	0010015131
VPS 800/3-5 INT	0010015132
VPS 1000/3-5 INT	0010015133
VPS 1500/3-5 INT	0010015134
VPS 2000/3-5 INT	0010015135

3 Description of the unit and functions

3.1 Design

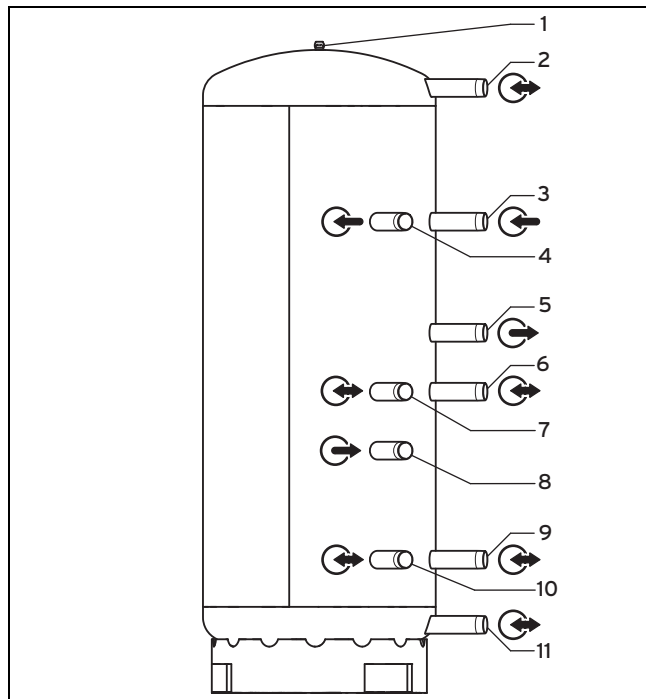

- | | |
|--------------------------------------|---|
| 1 Opening for purging valve | 6 Boiler flow for hot water demand/heating circuit flow |
| 2 Flow or return for cascade | 7 Boiler flow for hot water demand/heating circuit flow |
| 3 Boiler flow for hot water demand | 8 Boiler return for hot water demand |
| 4 Boiler flow for hot water demand | |
| 5 Boiler return for hot water demand | |

- | | |
|--|-------------------------------|
| 9 Boiler return for hot water demand/heating circuit return | 11 Flow or return for cascade |
| 10 Boiler return for hot water demand/heating circuit return | |

The buffer cylinder is made of steel. Its exterior has a coating of black anti-rust paint.

The buffer cylinder has:

- Connections for pipelines:
 - Heating circuits
 - Boilers
 - Other heat sinks and sources
- A purging valve
- Eight sensor straps

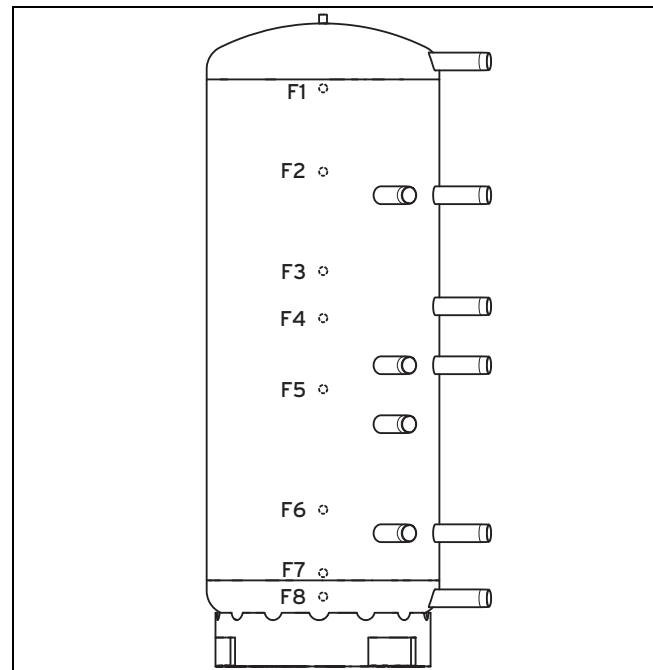

- | | |
|-------------------|-------------------|
| F1 Sensor strap 1 | F5 Sensor strap 5 |
| F2 Sensor strap 2 | F6 Sensor strap 6 |
| F3 Sensor strap 3 | F7 Sensor strap 7 |
| F4 Sensor strap 4 | F8 Sensor strap 8 |

The position of the sensors on the buffer cylinder sensor straps depends on the boiler that is used.

3.2 Functionality

The buffer cylinder is supplied with the heat from one or more heat generators. The buffer cylinder is used as an intermediate cylinder for heating water to be further transported to the heating circuit or other heat sinks.

4 Installation

4 Installation

4.1 Checking the scope of delivery

- ▶ Check that the scope of delivery is complete.

Quantity	Name
1	Buffer cylinder
1	Purging valve
1	Upper heat insulation
1	Lower heat insulation (footpad)
2/3	Side heat insulation
2/3	Cover strips
1	Cover
4	Thermal insulation caps
10	Collars
1	Identification plate sticker
1	Operating instructions
1	Installation and maintenance instructions

4.2 Checking the requirements for the installation site



Caution.
Material damage due to frost

Frozen water in the system can damage the heating installation and the installation room.

- ▶ Install the buffer cylinder in a dry, permanently frost-free room.



Caution.
Material damage due to escaping heating water

In the event of damage, all of the heating water from the heating installation may escape from the buffer cylinder.

- ▶ Select the installation site so that, in the event of damage, large volumes of water can be drained safely (e.g. into a floor drain).



Caution.
Material damage due to high load

Due to its weight, the filled buffer cylinder may damage the floor.

- ▶ When selecting the installation site, note the weight of the filled buffer cylinder and the load-bearing capacity of the floor.
- ▶ If necessary, ensure the foundation is suitable.

- ▶ Choose an installation site that complies with the requirements.

4.2.1 Observing the minimum clearances

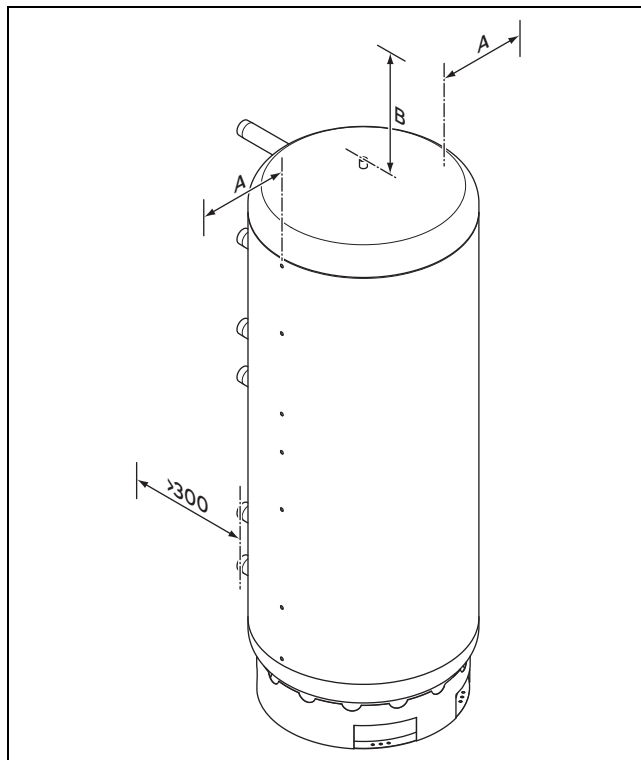

1. During installation, make sure there is sufficient clearance from the walls (**A**) and the ceiling (**B**).

Type designation	Side clearance A [mm]	Ceiling clearance B [mm]
VPS 300/3	350	350
VPS 500/3	450	
VPS 800/3	500	
VPS 1000/3	500	
VPS 1500/3	600	
VPS 2000/3	650	

2. Take into consideration the height and position of the pipelines.

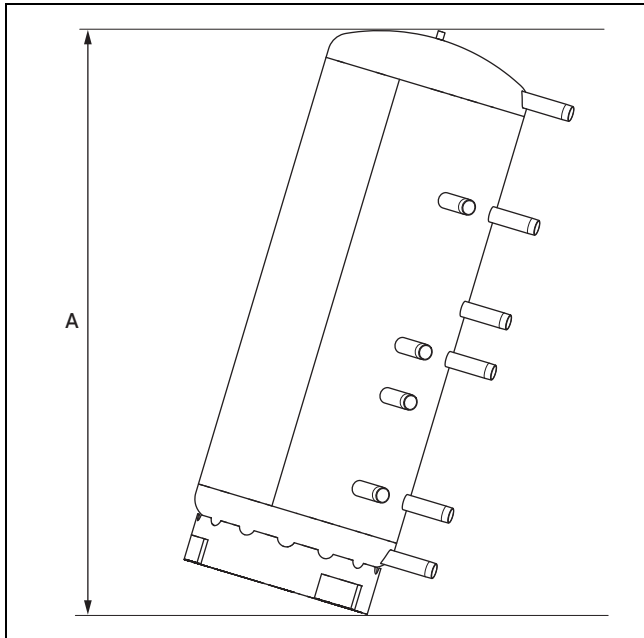

A Tilt measurement

- When selecting the installation room, note the tilt measurement of the buffer cylinder.

Type designation	Unit	Tolerance	Tilt measurement A
VPS 300/3	mm	± 20	1734
VPS 500/3	mm	± 20	1730
VPS 800/3	mm	± 20	1870
VPS 1000/3	mm	± 20	2243
VPS 1500/3	mm	± 20	2253
VPS 2000/3	mm	± 20	2394

4.3 Transporting the buffer cylinder



Danger!
Risk of injury and material damage due to improper transport

The screwed connections on the support rim may become loose if stored in an angled position. The buffer cylinder may tip over from the pallet and injure someone.

- ▶ Transport the buffer cylinder on the pallet using a fork-lift truck.
- ▶ Carry the buffer cylinder without a pallet, for example when carrying it downstairs.



Caution.
Risk of damage to the threads

Unprotected threads may be damaged during transport.

- ▶ Only remove the protective thread caps once at the installation site.

- Wear gloves to ensure that the heat insulation does not become dirty.



Note

The buffer cylinder can remain on the pallet during transport.

- Transport the buffer cylinder to the installation site.
- Install the buffer cylinder as close as possible to the heat generator.
- Select the installation site so that the pipes can be easily routed.
- Make sure that the base is level and stable.
- Remove the protective sleeve from the buffer cylinder.
- Retain the protective case.
 - ◁ The protective sleeve is pulled over the buffer cylinder again after the heat insulation has been installed.
- Remove the screwed connections from the support ring.
- Transport the buffer cylinder to the installation site.
- Transport the heat insulation and the cover strips to the buffer cylinder.

4.4 Unpacking and setting up the buffer cylinder



Caution.

Risk of damage to the threads

Unprotected threads may be damaged during transport.

- ▶ Only remove the protective thread caps once at the installation site.

- Carefully remove the protective film from the buffer cylinder without damaging the anti-rust paint.
- Align the buffer cylinder in such a way that it is vertical and does not tilt.
- Set up the buffer cylinder at the installation site. Observe the connection dimensions (→ Page 12).

4.5 Preparing the piping

- Position the cylinder temperature sensor in accordance with the section "Hydraulic scheme".
- Install the purging valve.
- Seal unnecessary connections using hydraulic caps.

4.6 Installing the heat insulation



Note

To make the work easier:

First, install the sensors in the sensor straps.

Install the purging valve.

Then, install the heat insulation.

Then install the piping for the buffer cylinder with the heating circuits and the heat generators.

4 Installation

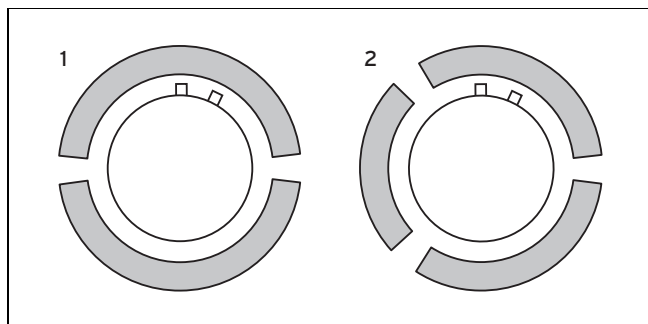

1 VPS 300/3, VPS 500/3, VPS 800/3, VPS 1000/3
2 VPS 1500/3, VPS 2000/3

1. Depending on the type of buffer cylinder, note the installation positions of the heat insulation (1, 2).

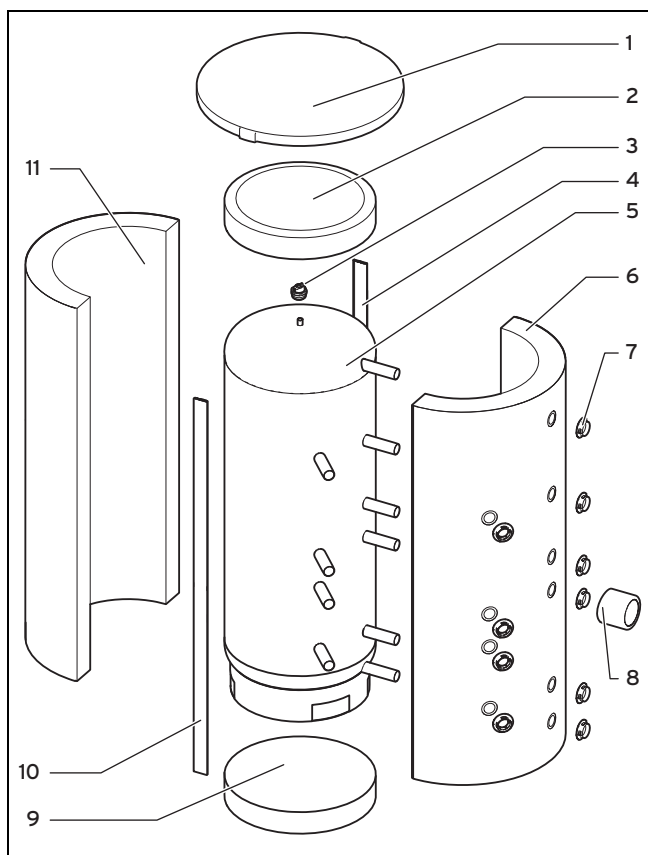

1 Cover	7 Collar
2 Upper heat insulation	8 Thermal insulation cap
3 Purging valve	9 Lower heat insulation
4 Cover strip	10 Cover strip
5 Buffer cylinder	11 Side heat insulation
6 Side heat insulation	



Caution.
Material damage due to low temperatures

Risk of the heat insulation breaking at temperatures below 10 °C.

- ▶ Install the heat insulation in a room where the room temperature is at least 10 °C.
- ▶ Wait until the heat insulation has adapted to the room temperature.

2. Remove the heat insulation from the packaging.
3. Tilt the cylinder slightly and clamp in the lower heat insulation below the mounting foot.
4. Install all required sensors in the sensor straps.



Caution.
Material damage due to escaping heating water

Heating water may escape from unused connections and cause material damage.

- ▶ Seal the connections that are not required with tightly sealed caps before attaching the insulation.

5. Remove the fleece residues from the heat insulation cut-outs.
6. Install the lateral heat insulation by guiding the heat insulation cut-outs over the buffer cylinder pipes.

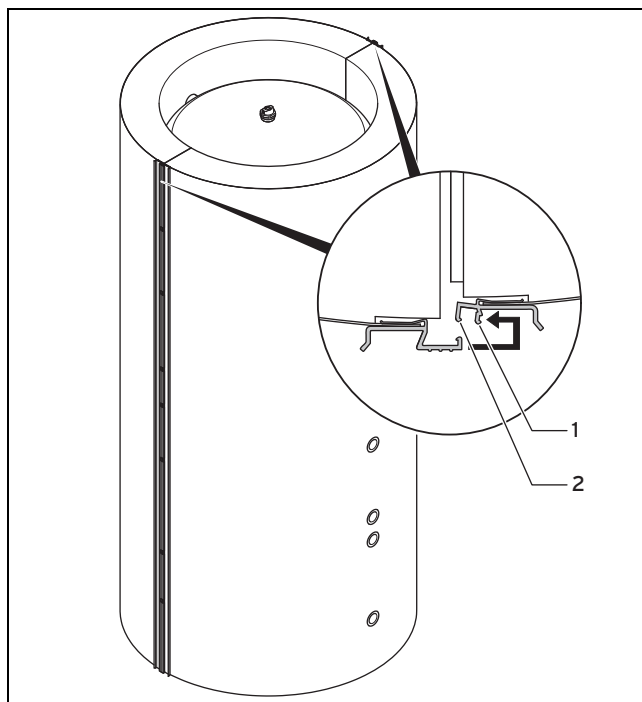

1 Last catch 2 First catch

7. Press the heat insulation onto the buffer cylinder so that the terminal strips between the two layers of heat insulation engage in the first catch (2).
8. Press the remaining terminal strips into the first catch.
9. Press the terminal strips between the two heat insulation layers together until the last catch (1).
10. Press the remaining terminal strips together until the last catch.
11. Clip on the cover strips.
12. Fit the collars on the buffer cylinder connections.
13. Place the thermal insulating caps over the unused connections and clip them in.
14. Pull the protective sleeve over the buffer cylinder.

4.7 Installing the buffer cylinder piping

1. Install the piping for the rear connections first.



Danger!
Material damage caused by foreign bodies in the heating installation

Residue from the pipelines, such as welding residue, scale, hemp, cement, rust, coarse dirt, etc. may form deposits in the buffer cylinder and disrupt operation.

- ▶ Remove residue by carefully rinsing the heating installation before connecting the buffer cylinder.

2. Design the expansion vessel in accordance with the rules regarding heating water and the heating installation.
3. Install the expansion vessel.
4. Pipe the buffer cylinder with the heating circuits and the heat generators in accordance with the section "Hydraulic scheme".

5 Start-up

1. Remove the protective sleeve from the buffer cylinder.
2. Carry out the initial start-up and carry out each restart of the buffer cylinder in accordance with the section "System in operation".

5.1 Filling and purging the buffer cylinder

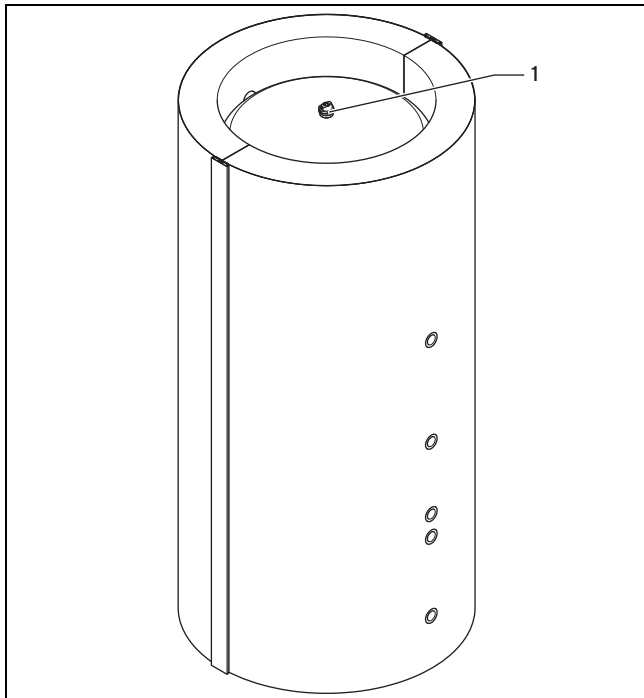

1 Purging valve

1. Open the purging valve (1).
2. Fill the system in accordance with the section "Filling and purging the system" until the buffer cylinder has been purged.
3. Close the purging valve.

4. Check that the purging valve is leak-tight.

5.2 Completing start-up

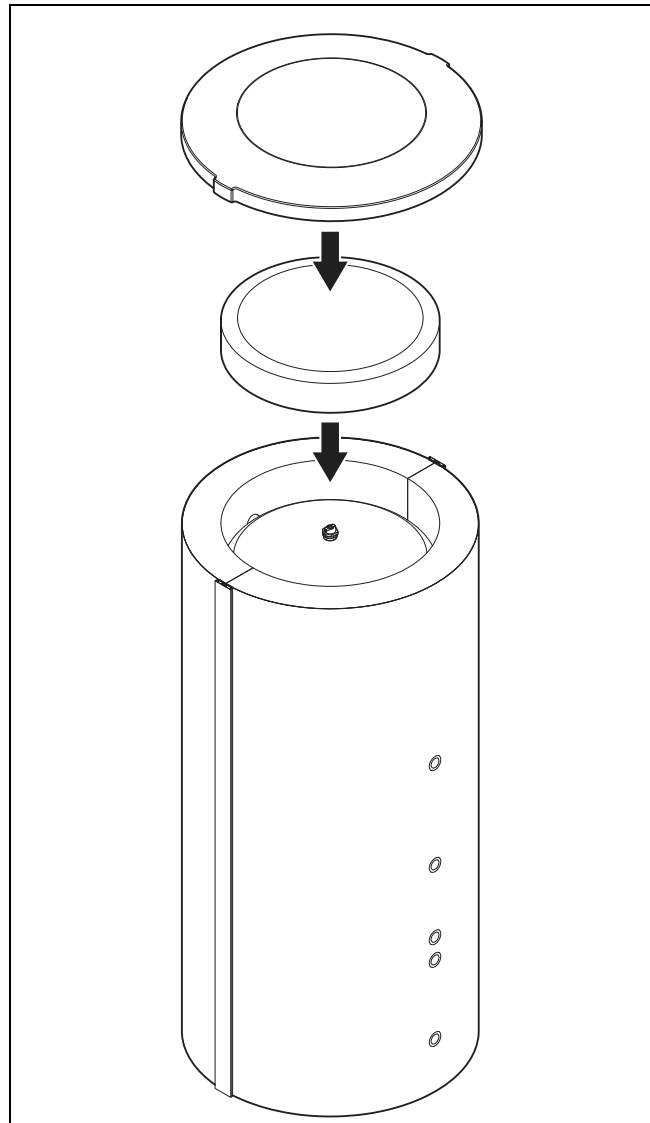

1. Press on the upper heat insulation between the lateral heat insulation until it is positioned securely.
2. Place the cover on the upper heat insulation.

6 Handing over to the operator

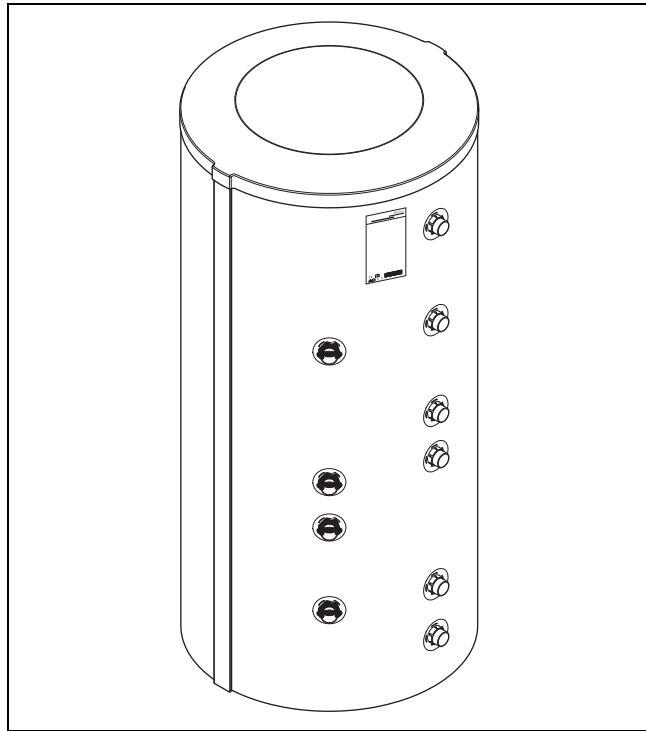

3. Stick the identification plate to the rear of the heat insulation.

6 Handing over to the operator

1. Inform the operator about how to handle the system. Answer any questions the operator may have. In particular, draw attention to the safety information which the operator must follow.
2. Instruct the operator that, when filling the heating installation, the water quality available on site must be taken into consideration.
3. Inform the operator that, when filling the heating installation, they must only use normal tap water without any chemical additives.
4. Explain to the operator how the safety devices work and where they are located.
5. Inform the operator of the necessity to have the system maintained according to the specified intervals.
6. Provide the operator with all relevant instructions and unit documentation for safe-keeping.

7 Troubleshooting

The following table provides information about potential faults when operating the buffer cylinder, along with their causes and how to eliminate them.

Fault	Possible cause	Remedy
Heating water drips out of the buffer cylinder.	Leaking connections	Seal the connections.
Splashing noises can be heard from the buffer cylinder.	There is air in the buffer cylinder	Purge the buffer cylinder.

Fault	Possible cause	Remedy
The controller displays an incorrect cylinder temperature.	Defective heat sensor or the heat sensor is positioned incorrectly	Check that the heat sensor is positioned correctly in accordance with the installation instructions for the allSTOR buffer cylinder system. Replace the heat sensor.

8 Inspection, maintenance and spare parts

8.1 Maintenance plan

No.	Maintenance work	Interval	Page
1	Checking the connections for leaks	Annually	10
2	Purging the buffer cylinder	Annually	10
3	Filling the buffer cylinder	Annually	10
4	Check the connections, heat insulation and components for damage	Annually	10
5	Caring for the product	Annually	10

8.2 Checking the connections for leaks

- ▶ Check all threaded connections for leaks.

8.3 Purging the buffer cylinder

- ▶ Purge the system in accordance with the section "Filling and purging the system".

8.4 Filling the buffer cylinder

- ▶ Fill the system in accordance with the section "Filling and purging the system".

8.5 Check the connections, heat insulation and components for damage

- ▶ Check all of the connections and the buffer cylinder heat insulation, along with the connected components, for damage.

8.6 Caring for the product



Caution.

Risk of material damage caused by unsuitable cleaning agents.

- ▶ Do not use sprays, scouring agents, detergents, solvents or cleaning agents that contain chlorine.
- ▶ Clean the casing with a damp cloth and a little solvent-free soap.

8.7 Procuring spare parts

Information about available Vaillant genuine spare parts is available by contacting the contact address provided on the reverse of this document.

- ▶ If you require spare parts for maintenance or repair work, use only Vaillant genuine spare parts.

9 Decommissioning

9.1 Emptying the buffer cylinder



Danger!

Risk of death from live connections!

When working in electronics boxes of system components that are connected to the low-voltage network (230 V), there is a risk of death from electric shock. Continuous voltage is present on the mains connection terminals, even if the main switch is turned off.

- ▶ Disconnect the system components from the power mains by disconnecting the mains plug or by de-energising the system components via a partition with a contact opening of at least 3 mm (e.g. fuses or power switches).
- ▶ Secure the power supply against being switched back on again.
- ▶ Check that there is no voltage in the system components.
- ▶ Open the electronics box only when the system components are disconnected from the power source.

Conditions: Heating circuits should not be drained

- ▶ Close the heating circuits on the isolator devices.
1. Connect a drain hose to the lowest-lying drain cock in the buffer cylinder circuit.
 2. Feed the drain hose into a suitable drain (floor drain, sink).
 3. Open the drain cock.
 4. Remove the cover from the buffer cylinder.
 5. Remove the upper heat insulation from the buffer cylinder.
 6. Open the purging valve on the buffer cylinder.
 - ◀ The water flows out of the buffer cylinder.

9.2 Decommissioning components

- ▶ Decommission the individual components of the **allSTOR** buffer cylinder system in accordance with the applicable installation instructions.

10 Recycling and disposal

Disposing of the packaging

- ▶ Dispose of the packaging correctly.

Disposing of the product and accessories

- ▶ Do not dispose of the product or the accessories with household waste.
- ▶ Dispose of the product and all accessories correctly.
- ▶ Observe all relevant regulations.

11 Technical data

11 Technical data

11.1 Connection dimensions

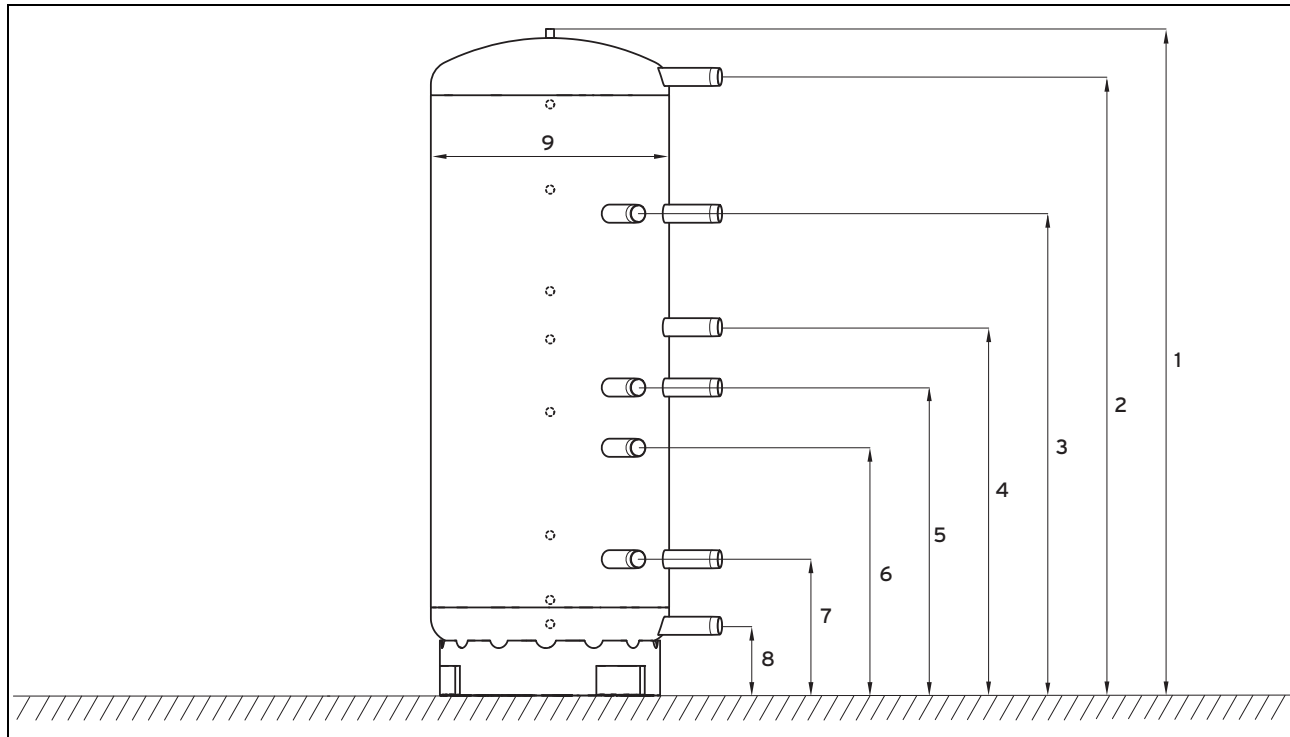

Di- men- sion	Unit	Toler- ance	VPS 300/3	VPS 500/3	VPS 800/3	VPS 1000/3	VPS 1500/3	VPS 2000/3
1	mm	± 10	1720	1700	1832	2212	2190	2313
2	mm	± 10	1617	1570	1670	2051	1973	2080
3	mm	± 10	1210	1230	1330	1598	1573	1656
4	mm	± 10	920	930	1020	1220	1227	1201
5	mm	± 10	744	750	820	1020	1000	1008
6	mm	± 10	574	579	636	822	797	803
7	mm	± 10	365	394	421	451	521	551
8	mm	± 10	130	190	231	231	291	298
9	mm	± 2	Dia. 500	Dia. 650	Dia. 790	Dia. 790	Dia. 1000	Dia. 1100

11.2 Technical data table

Description	Unit	Toler- ance	VPS 300/3	VPS 500/3	VPS 800/3	VPS 1000/3	VPS 1500/3	VPS 2000/3
Cylinder tank capacity	l	± 2	303	491	778	962	1505	1917
Perm. system overpressure (heating side)	MPa (bar)	—	0.3 (3)					
Heating water temperature	°C	—	95					
Cylinder tank outer diameter (without heat insulation)	mm	± 2	500	650	790	790	1000	1100
Cylinder tank outer diameter (with heat insulation)	mm	± 10	780	930	1070	1070	1400	1500
Cylinder tank depth (incl. heat insulation and connections)	mm	± 10	828	978	1118	1118	1448	1548
Cylinder tank height (incl. pur- ging valve and positioning ring)	mm	± 10	1735	1715	1846	2226	2205	2330
Buffer cylinder height (incl. heat insulation)	mm	± 10	1833	1813	1944	2324	2362	2485

Description	Unit	Tolerance	VPS 300/3	VPS 500/3	VPS 800/3	VPS 1000/3	VPS 1500/3	VPS 2000/3
Cylinder tank weight (empty)	kg	± 10	70	90	130	145	210	240
Cylinder tank weight (full)	kg	± 10	373	581	908	1107	1715	2157
Tilt measurement	mm	± 20	1734	1730	1870	2243	2253	2394
Standby energy consumption	KWh/24 hrs	—	< 1.7	< 2.0	< 2.4	< 2.5	< 2.9	< 3.3

11.3 Connection sizes

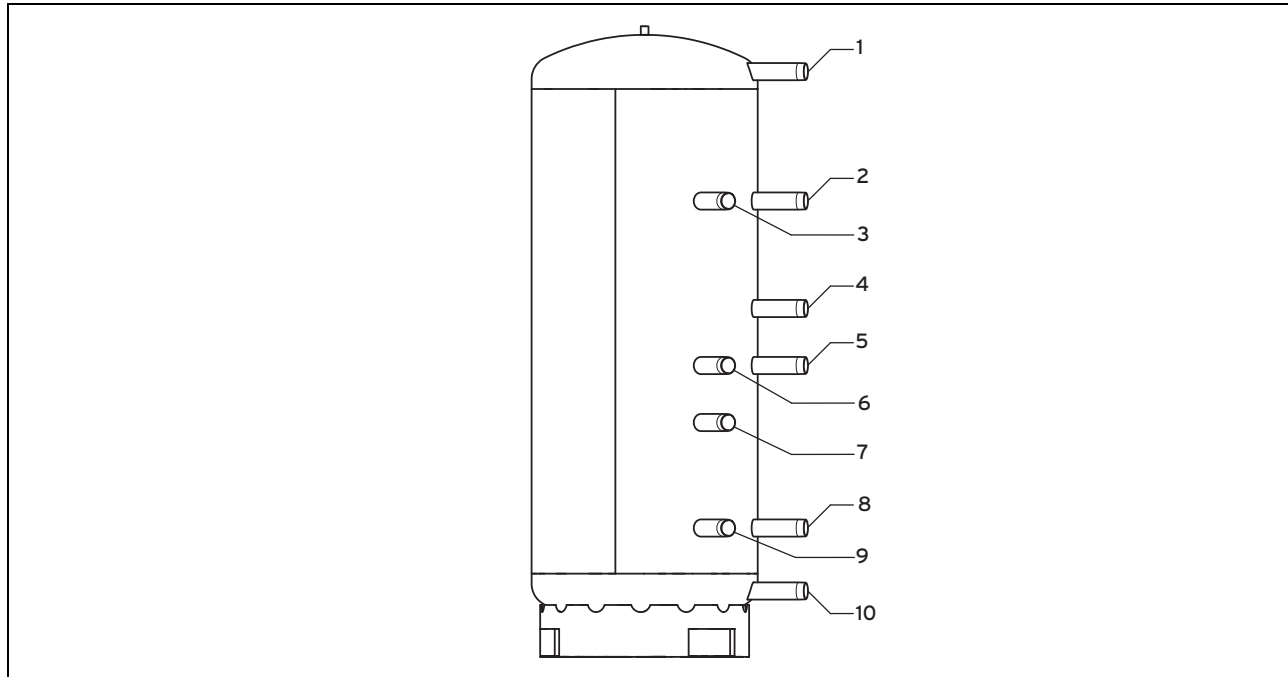

	Rear connections
	Item no. 1, 2, 3, 4, 5, 6, 7, 8, 9, 10
VPS 300/3	R 1 1/2
VPS 500/3	
VPS 800/3	R 2
VPS 1000/3	
VPS 1500/3	R 2 1/2
VPS 2000/3	

12 allSTOR buffer cylinder system

12 allSTOR buffer cylinder system

This section describes examples of how the **allSTOR** buffer cylinder can be integrated into various systems.



Danger!

Risk of death caused by incorrect installation of the system

An incorrectly installed system may cause both personal injury and material damage.

- ▶ Plan the system in accordance with the regulations of the country in which the system is to be installed.

- ▶ Request planning information from Vaillant.

12.1 System description

The **allSTOR** buffer cylinder system can be used to operate:

- Heating installations with hot water generation
- Pure heating installations (no hot water generation)
- Pure hot water installations (no heating)

The **allSTOR** buffer cylinder system consists of a **VPS/3** buffer cylinder and at least one other component. The following buffer cylinders and components are available:

- Buffer cylinder
 - **VPS 300/3**
 - **VPS 500/3**
 - **VPS 800/3**
 - **VPS 1000/3**
 - **VPS 1500/3**
 - **VPS 2000/3**

12.2 Designing the system

- ▶ Ensure that the system has been planned in accordance with the codes of practice and the applicable planning standards.
- ▶ Observe the planning information for the units that are to be integrated.
- ▶ Observe the same hydraulic schemes, see section "Hydraulic scheme".
- ▶ Note the following points in the event of dimensioning that is tailored to needs:

VPS/3 buffer cylinder

- Hot water demand
- Heat demand
- Type of boiler (running time, bridging time)
- Solar storage time

Heating expansion vessel

- System volume (incl. buffer cylinder)
- System height or expansion-vessel pre-charge pressure
- Water trap

Boilers

- Building heat demand while taking into consideration the solar yields
- Technologies:

- Floor-standing oil-fired boilers/oil-fired high-efficiency units
- Floor-standing gas-fired boilers/gas-fired high-efficiency boilers/gas-fired boilers
- Pellet boiler
- Heat pumps (water, brine, air)

Circulation pump

- Actuation
- Residual head
- Volume flow

eBUS lines

- Line cross-section: At least 0.75 mm²
- Further information: See **Installation instructions for the VRS 620/3 solar system controller**

Connection and extra-low voltage lines

- Information on connection and extra-low voltage lines: See the **installation instructions** for the units

Heating circuits

- Any number of heating circuits is possible (depends on the controller)
- Heating circuit types:
 - Static heating surfaces
 - Underfloor heating surfaces
 - Home stations
- Underfloor heating surfaces:
 - Max. flow temperature 40° C
- Regulated heating circuits:
 - Regulated heating circuits only
- Maximum total output of the heating circuits:
 - **VPS 300/3**: 8 m³/h
 - **VPS 500/3**: 8 m³/h
 - **VPS 800/3**: 15 m³/h
 - **VPS 1000/3**: 15 m³/h
 - **VPS 1500/3**: 30 m³/h
 - **VPS 2000/3**: 30 m³/h

12.3 Hydraulic scheme

Information on piping the **VPS/3-5 INT** can be found in the planning information from Vaillant.

The planning information from Vaillant, along with further information, is available for:

- The buffer cylinder
- The individual boilers

12.3.1 Hydraulic scheme

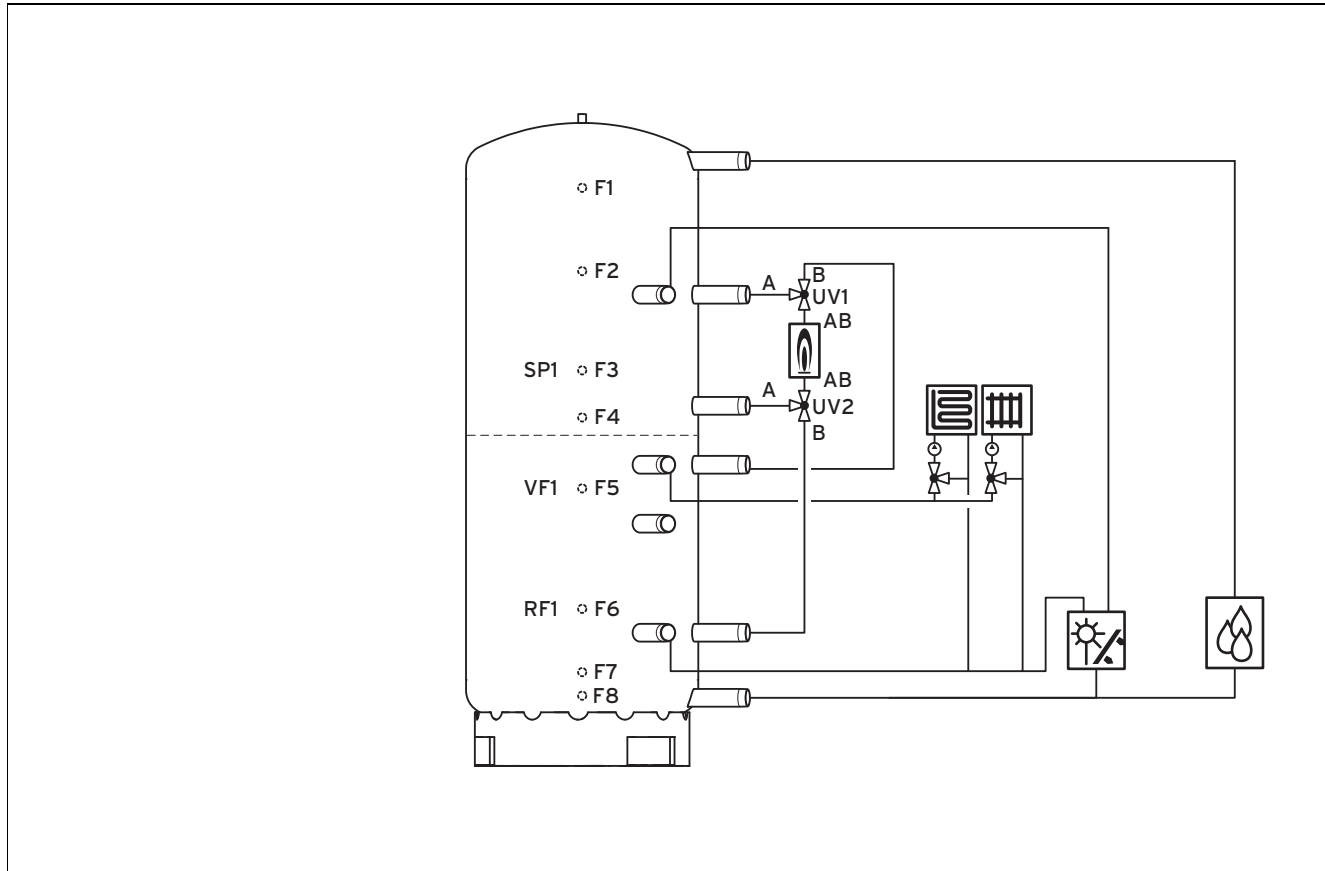

F3	SP1 = Cylinder temperature sensor (all)	F6	RF1 = Return temperature sensor/cylinder temperature sensor
F5	VF1 = Flow temperature sensor 1/cylinder temperature sensor/low loss header temperature sensor	UV1	Diverter valve 1
		UV2	Diverter valve 2

Diverter valve 2 (UV2) is located outside or inside the product, depending on the boiler type.

13 Customer service

12.4 Starting up the system

12.4.1 Filling and purging the system

- ▶ Observe the installation instructions for the units.
- ▶ Fill and purge the heating circuit.
- ▶ Fill and purge the buffer cylinder.



Caution.

The use of unsuitable heating water may cause aluminium corrosion and a resulting lack of leak-tightness.

In contrast to steel, grey cast iron or copper, for example, aluminium reacts with alkaline heating water (pH value > 8.5) to produce substantial corrosion.

- ▶ When using aluminium, make sure that the pH value of the heating water is between 6.5 and a maximum of 8.5.

Mixing additives with the heating water may result in material damage. However, no incompatibility with Vaillant units has been detected with proper use of the following products over a long period.

- ▶ When using additives, follow the manufacturer's instructions without exception.

Vaillant accepts no liability relating to the compatibility or efficacy of any additives in the rest of the heating system.

Additives for cleaning measures (subsequent flushing required)

- Fernox F3
- Sentinel X 300
- Sentinel X 400

Additives intended to remain permanently in the system

- Fernox F1
 - Fernox F2
 - Sentinel X 100
 - Sentinel X 200
- ▶ Inform the operator about the measures required if you have used these additives.

13 Customer service

To ensure regular servicing, it is strongly recommended that arrangements are made for a Maintenance Agreement. Please contact Vaillant Service Solutions (0870 6060 777) for further details.

0020200898_00 ■ 20.10.2014

Vaillant Ltd

Nottingham Road ■ Belper ■ Derbyshire ■ DE56 1JT
Telephone 44 84 56 02 29 22 ■ Vaillant Service Solutions 44 807 06 06 07 77
Spares Technical Enquiries 44 17 73 59 66 15
info@vaillant.co.uk ■ technicalspares@groupservice.co.uk
www.vaillant.co.uk

© These instructions, or parts thereof, are protected by copyright and may be reproduced or distributed only with the manufacturer's written consent.