

recoVAIR



Mechanical ventilation
and heat recovery
system

recoVAIR VAR275
recoVAIR VAR350

Vaillant leaders in innovation



ecoTEC exclusive



recoVAIR mechanical ventilation and heat recovery system

Europe's No.1

When it comes to creating the ideal living environment, at home, in the office or even at your favourite restaurant Vaillant has it all under control. For more than 130 years, we have been setting the standards in the heating market, developing products that have revolutionised the industry. And today we are proud to be Europe's No.1 boiler manufacturer with an enviable reputation for performance, efficiency, quality and reliability. But staying on top requires constant innovation. So we continually invest in developing new technologies for even better solutions - all designed to create the perfect climate for all situations.

New technologies

As you would expect from Europe's No. 1 domestic heating product manufacturer, our range of products boast class leading features and controls, the highest efficiency ratings and unrivalled after sales back-up. But improving traditional products is just one of our aims, with global temperatures continuing to rise and traditional energy fuel stocks diminishing, the challenge now is to find new ways of providing the comfort we have all come to expect.

Energy efficient, advanced technology



aurotherm exclusive

Energy efficiency and renewable energy

Both governments and consumers are demanding more efficient and more environmentally friendly heating and ventilation solutions to help conserve our planet for future generations. Vaillant has embraced this wholeheartedly, as you would expect, and by conducting extensive research and development have not only produced a range of energy efficient innovative products such as ground source heat pumps and solar thermal water heating but are also at the forefront of the development of the energy saving products of the future.

Commitment

Vaillant is committed to the development of effective renewable energy systems which are crucial to the future efficiency and environmental well being of us all and will continue to strive to lead the market in these technologies.

Heat recovery ventilation clean efficient fresh air



recoVAIR mechanical ventilation and heat recovery system

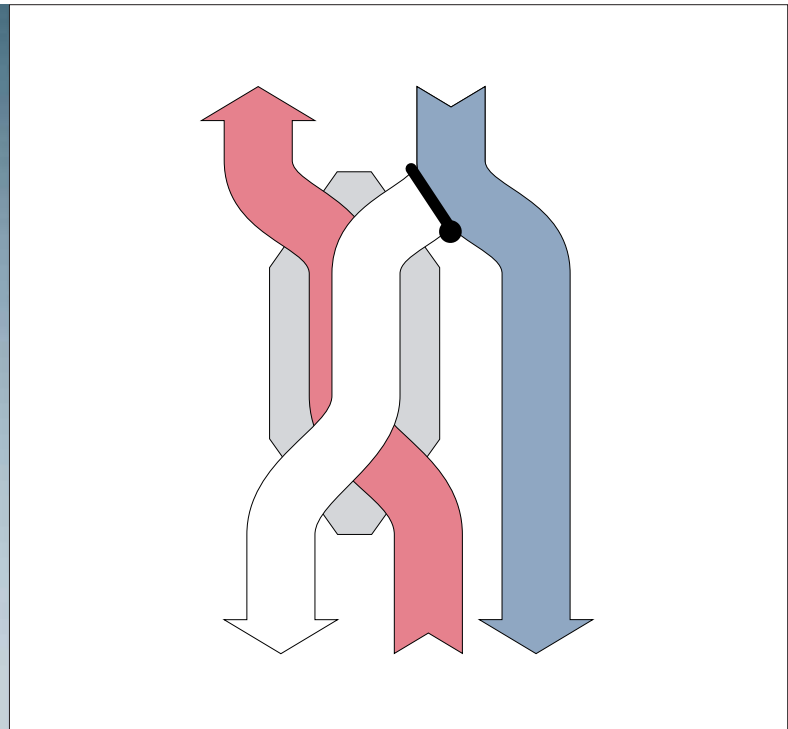

Air flow and heat exchange

recoVAIR mechanical ventilation and heat recovery system

Mechanical ventilation and heat recovery means everyone in the home can have all the fresh air they require without having to pay the energy cost for heating it up to a comfortable temperature. The recoVAIR system also reduces the carbon footprint of the home, reducing the reliance on fossil fuels needed to effectively heat up the property.

How does recoVAIR work?

The recoVAIR system extracts used air from the home and at the same time uses the heat from the extracted air to heat up fresh air from outside.

The recoVAIR system has two integral speed controlled DC fans, one for the supply of air and the second for extraction. The air flows are managed so that each passes through the heat exchanger in a 'contra-flow' to provide maximum heat transfer (up to 95%) from the extracted air to the fresh air supply. This brings the temperature of the fresh air close to the room temperature, reducing the amount of additional heat needed to match the temperature to the occupant's requirements.

Automatic summer by-pass

Each recoVAIR system is supplied with a summer by-pass unit, this allows the cooler summer night-time fresh air to by-pass the heat exchanger providing an immediate cooling effect as well as pre-cooling the building fabric prior to the next warm day. The standard controller even provides an energy gain display to show you how much energy is saved in using this feature.



recoVAIR remote control

Ease of installation

To assist in the installation of your recoVAIR system each comes with a multi-sized connection flange allowing up to three different size ducts to be simply attached to the unit without the need for additional reducers.

Controls

Each recoVAIR system comes complete with a Vaillant easy to use multi-function controller. The controller is used to set up the required air volume for the building, set times for normal, low and boost operation, automatically set by-pass control and provides energy saving (gain) information as well as multiple diagnostic and servicing indications.



recoVAIR and by-pass unit

recoVAIR mechanical ventilation and heat recovery system range

recoVAIR VAR 275

From 50m³/h up to a maximum of 275m³/h @ 175pa

recoVAIR VAR 350

From 70m³/h up to a maximum of 350m³/h @ 265pa

Ventilation the air that we breathe



The need for ventilation

Each and every one of us requires fresh air to survive, with each person exhaling between 10 and 75 litres of carbon dioxide and 175 grammes of water vapour per hour. A family of four produces between 10 and 15 litres of water vapor each day through cooking, washing and breathing. Dust mites have proven links with over 80% of asthma cases and thrive when humidities are high. What's more within a typical home there are traces of ammonia, acetic acid, methane, nitrogen monoxide and formaldehyde from cleaning products and building materials.

Unless ventilation is added these contaminants will linger within the home and will affect both the health of the occupants and can lead to damage to the fabric of the building itself. A well designed fresh air system can reduce these levels significantly, replacing contaminants with clean fresh air.



Building Regulations

The new homes of today have greatly reduced levels of natural ventilation which reduces heat loss, positively contributing to the energy efficiency of the property. However, a lack of proper ventilation can lead to a build up of contaminants that can affect the health of a building's occupants. The need for ventilation in new homes is so important that a section of the building regulations (part F) is devoted solely to this issue. Part F recognises the role to be played by heat recovery ventilation to not only meet the ventilation requirement but also to comply with the energy efficiency requirements of the building regulations.

recoVAIR frequently asked questions

Why is a ventilation system needed?

Current buildings regulations require all new dwellings to have almost no air loss to reduce the amount of energy needed to heat the building. However everyone needs a supply of fresh air for their continued health and well being.

The regulations recognize this and provide guidelines for introducing a controlled amount of fresh air into new homes.

Why choose a heat recovery ventilation system?

Even though the amount of fresh air introduced is controlled, this air will be at outside temperature and will need to be heated to match the room temperature. Heat recovery units exchange the heat that is extracted with the fresh air as it is introduced, without transferring any of the pollutants the extracted air may contain, and so the amount of additional heat that is required is significantly reduced.

Can this system be fitted to any home?

To be most effective the house needs to be sealed so that the air flows can be controlled, this means the system is most effective in new properties built to the latest standards. However, provided it can be correctly sealed and insulated any property can benefit from installing a recoVAIR unit.

Why choose a Vaillant recoVAIR system?

Vaillant as the leader in domestic heating solutions is justifiably proud of their recoVAIR system. It has the class leading features and quality that you would expect from a Vaillant product.

Yes, but what is so good about the recoVAIR units?

- **Maximum energy efficiency.** The unit is capable of recovering up to 95% of the heat from the exhaust air.
- **Low running costs.** The recoVAIR unit uses DC speed controlled fans which can be exactly matched to the ventilation requirements, reducing the need for wasteful and noisy duct dampers.
- **System controls.** Vaillant's unique control system allows the installer to set up and commission the unit from the controller. The LCD display, as well as giving an instant read out of temperature and air flows, also provides instant access to all settings and allows the owner to set their own parameters as required.

Can the recoVAIR system benefit asthma sufferers?

Up to 80% of asthma sufferers are affected by dust mites, that thrive in damp conditions (typically over 60% RH), heat recovery ventilation efficiently reduces humidity created by cooking, cleaning and washing thereby removing the conditions dust mites love.

Additionally, your recoVAIR unit can be fitted with optional high efficiency filtration to remove airborne contaminants, including pollen, which could aggravate the condition.

Does the recoVAIR system need to be switched on and off?

This system is designed to operate all year round, their low wattage fan motors ensure running costs are minimized.

The recoVAIR unit's standard remote control includes automatic timed day (high) and night operation (low) as well as holiday (minimum) and party (boost) available at a push of a button.

All recoVAIR systems also come with a summer by-pass as standard, this device automatically allows cooler night time air to be drawn directly into the house cooling the occupants and building fabric.

Who can install this system?

Installation of the recoVAIR mechanical ventilation and heat recovery system and ductwork should be undertaken by a suitable qualified professional.

Where does the unit go in the house?

Generally the unit is installed in the attic space or in a utility room or cupboard.

When do the filters need to be changed or cleaned?

To maintain the optimum efficiency of the unit and to ensure continued air quality, we recommend the filters are cleaned at least every six months and replaced annually. Units in particularly dirty atmospheres may require more frequent attention.

The recoVAIR system is fitted with a filter service indicator which automatically reminds you when filter attention is required.

Can the homeowner change the filters themselves?

Yes, the filters are easily accessed behind the front panel of the unit, but remember to isolate the power supply before attempting this.

What other servicing is required?

We recommend that the unit is checked annually for correct operation and cleaned by a qualified person. The service would include a check and clean (if necessary) of the heat exchangers and the filters would also be replaced.

How is the unit sized and selected?

The unit is selected based on the requirements of Building Regulations Part F which lays down the minimum ventilation requirements for new homes.

What about the ductwork?

The ductwork is designed to suit the requirements to provide the correct ventilation as well as ensure that undue strain is not put on the recoVAIR unit by excessive bends and restrictions.

What are the main benefits of fitting a recoVAIR unit?

The main benefits people have found from fitting one of our units are:

- No noticeable fungal (mould) growth in bathrooms or bedrooms.
- Little condensation on windows.
- Generally, people wake feeling refreshed as fresh air is circulated all through the night
- Fresher smelling bathrooms (air is constantly being changed so no need for air fresheners)

- Less dust (windows kept closed and all air entering the house is filtered)
- Feeling more secure (windows are kept closed even on warm summer nights due to the by-pass vent feature)
- Quieter house less outside noise as windows are kept closed, no noisy bathroom extract fans.

Does the home need a heating system as well as the recoVAIR system?

Yes. The recoVAIR system reduces energy costs by recovering what would normally be waste heat but the home still needs to be heated using a conventional system. For the latest information about Vaillant heating systems please visit www.vaillant.co.uk

The recoVAIR system will improve the air in the home but is it expensive to operate?

Actually, compared to other forms of ventilation such as trickle vents with extract fans and passive stack ventilation systems, the recoVAIR system will reduce your heating costs. Individual extract fans are normally selected on a 'one size fits all' principle and typically move excessive amounts of air (and therefore heat) for the period they operate.

Although heat recovery ventilation is designed to operate 24/7 the energy saved by recovering the heat from the exhaust air more than compensates for this.

What are the consequences of poor ventilation?

The possible effects of a lack of sufficient ventilation to a home include:

- Strong multiplying of micro organisms and house dust mites
- Possible health problems
- Increase in allergies
- Headache and nausea
- Damage to the building structure and furnishings
- Build up of carbon dioxide and household odours



recoVAIR by-pass unit for automatic night time 'free' cooling

Dimensions

recoVAIR system unit dimensions

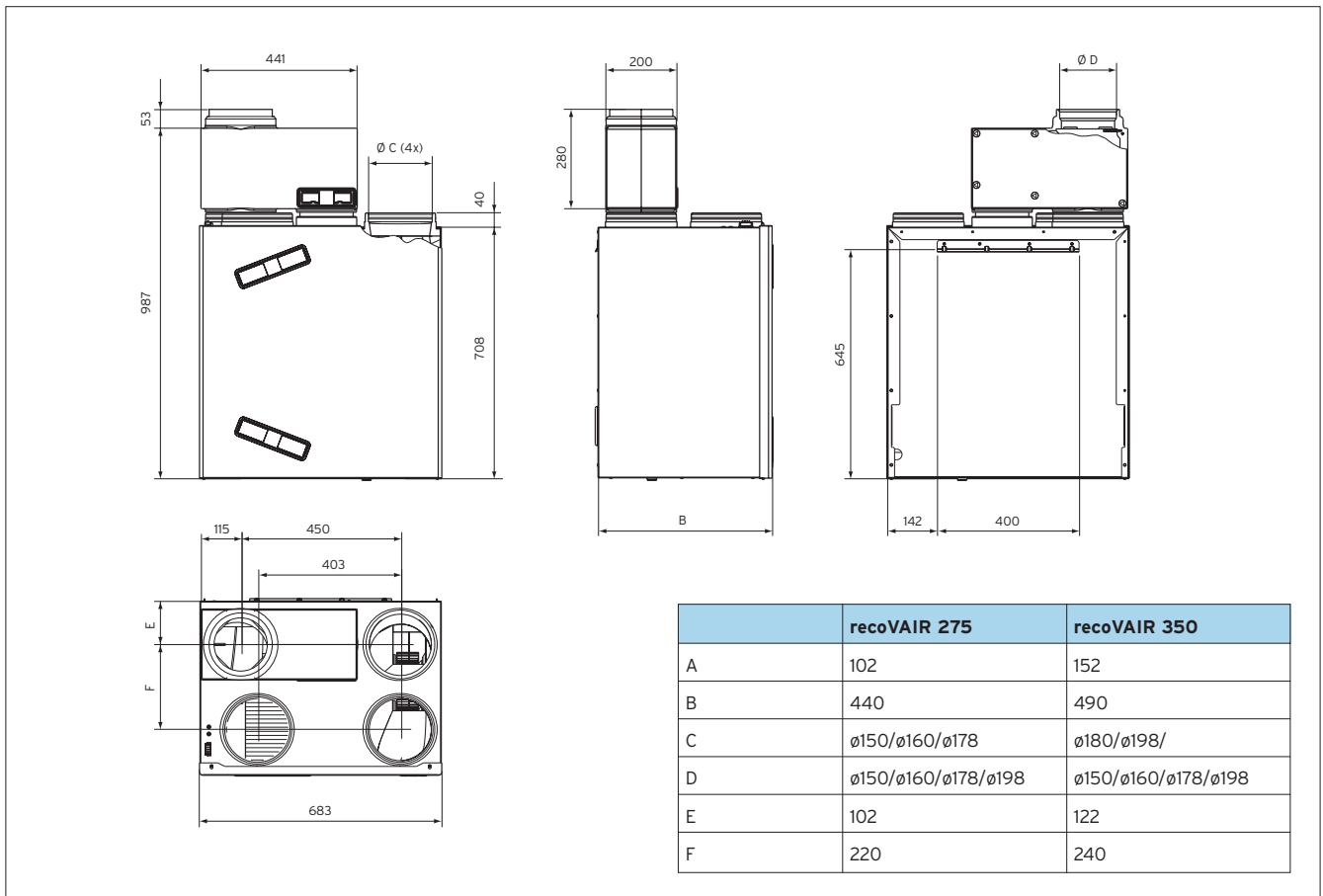

Features and benefits

Energy efficient

- Heat exchange efficiency of over 95%

Summer by-pass fitted as standard

- Automatic operation
- Display for energy saved
- Plug and play fitting
- Controls can be positioned up to 30m away from the main unit for maximum adaptability

Standard multi-function e-bus remote control

- Timer functions
- Extra-low and boost setting at a touch of a button
- Diagnostic display
- Temperature and unit performance read out

Feature packed construction

- Multi-size duct connections
- Long life aluminium heat exchanger
- Polypropylene internal construction for light weight and sound insulation
- Powder coated steel outer casing for durability
- DC speed controlled fan motors. Robust, quiet and infinitely speed controlled for maximum efficiency
- Optional high efficiency filters
- Vaillant quality
- Aluminium heat exchanger for light weight and maximum performance durability

Customer support services



Working in partnership

The after sales service and support behind every Vaillant product is part of the quality package that has helped us build a unique reputation within the industry. And it's an approach that's reflected in our support for our Vaillant air conditioning products. For example, there's the benefit of a comprehensive parts and labour guarantee which is backed up by our renowned parts supply chain and service facilities.

High quality training

Please contact our training team to register your interest in attending a Vaillant solar training course.

Contact details

Head Office

Vaillant Ltd., Vaillant House, Trident Close,
Rochester, Kent ME2 4EZ

Telephone 01634 292300

E-mail info@vaillant.co.uk

Sales

Telephone 01634 292310

Fax 01634 712804

E-mail sales@vaillant.co.uk

Contracts, Partnering & Leasing

Telephone 01634 292322

Fax 01634 292379

E-mail contracts@vaillant.co.uk

Technical

Telephone 01634 292392

Fax 01634 294504

E-mail technical@vaillant.co.uk

Training

Telephone 01634 292370

Fax 01634 292354

E-mail training@vaillant.co.uk

After Sales Service

Telephone 0870 8503073

Fax 01634 294506

E-mail service@vaillant.co.uk

Mon - Fri 8.30am - 5.30pm

Website www.vaillant.co.uk

Technical specification

		recoVAIR heat recovery ventilation	
System reference		VAR 275	VAR 350
Nominal air flow	m ³ /h	275	350
Nominal external static pressure	Pa	170	265
Maximum air flow	m ³ /h	275	350
Minimum air flow	m ³ /h	50	75
Maximum Efficiency	%	95.3	95.1
Unit dimensions	mm h x w x d	708x683x440	708x683x490
Nett weight	kgs	38	39
Packed dimensions	mm h x w x d	760x870x560	760x870x560
Gross weight	kgs	43	45
Filtration		G3	G3
Sound pressure level @ 1m	dbA	48	52
By-pass unit dimensions	mm	441x280x200	441x280x200
Power			
Voltage/Frequency	V/Hz	230/50	230/50
Power @ 30%	Watts	25	30
Power @ 60%	Watts	55	70
Power @ 100%	Watts	175	295
Connection sizes			
Supply air in	mm	150/160/180	180/200
Supply air out	mm	150/160/180	180/200
Extract air in	mm	150/160/180	180/200
Extract air out	mm	150/160/180	180/200
Operating temperatures			
Maximum operating temperature	°C	50	50
Minimum operating temperature	°C	-7	-7